

On-Board[®] *IS* Cryopump System Operation Guide

The information in this document is intended to provide a record of the system upgrade performed by Helix Technology Corporation. The system is defined within this document. These instructions are to be used by trained personnel who are experienced with servicing Helix Technology Corporation equipment.

Any correspondence regarding this document should be forwarded to:

Helix Technology Corporation
Mansfield Corporate Center
Nine Hampshire Street
Mansfield, Massachusetts 02048-9171 U.S.A.

Telephone: (508) 337-5000

FAX: (508) 337-5464

The following Helix Technology Corporation trademarks and service marks may appear in this document:

Conductron™	Convectron®	Cryodyne®	Cryogen®
Cryogenerator®	Cryo-Torr®	CTI-Cryogenics®	FastRegen™
GOLDLink®	Granville-Phillips™	GUTS®	Helix Technology.. Your Vacuum Connection SM
Helix®	Micro-Ion®	Mini-Ion™	On-Board®
RetroEase®	RetroFast®	Stabil-1®	Stabil-Ion®
ThinLine™	TurboPlus®	Vacuum Assurance SM	

All other trademarks or registered trademarks are the property of their respective holders.

Table of Contents

Figures..... v

Tables vii

Cryopump Safety

Introduction S-1

Warnings S-1

Cautions S-1

 Toxic, Corrosive, Dangerous Gases, or Liquids S-2

 Flammable or Explosive Gases S-2

 High Voltage S-2

 High Gas Pressure S-2

Cryopump Oxygen Procedures S-3

Section 1 - Getting Started

Introduction 1-1

Equipment Installation Verification 1-3

 On-Board IS Cryopumps 1-3

 On-Board IS-1000 Compressor 1-3

 On-Board IS Controller 1-3

 On-Board IS Remote 1-3

Helix Intercomponent Network Address Settings 1-3

 On-Board IS Cryopump Addresses 1-6

 On-Board IS-1000 Compressor Addresses 1-6

Selecting Screens and Changing Parameters 1-7

 Screen Selection 1-7

 Changing a Screen Parameter 1-7

System Power 1-8

 Turning Power On 1-8

 Turning Power Off 1-8

Equipment Address Verification 1-9

 Helix Intercomponent Network Addresses 1-9

 On-Board IS Cryopump Temperatures 1-10

 On-Board IS-1000 Compressor Information 1-11

Password Setup 1-12

What's Next? 1-12

Section 2 - Creating Rough and Helium Maps

Introduction 2-1

Roughing Maps 2-1

 Creating a Roughing Map 2-3

Helium Maps 2-3
 Creating a Helium Map 2-5
What's Next? 2-5

Section 3 - Regeneration

Introduction 3-1
Setting Regeneration Parameters 3-2
Regeneration Maps 3-3
Initiating a Full Regeneration Cycle 3-6
What's Next? 3-6

Section 4 - On-Board IS Controller Screen Descriptions

Introduction 4-1
 Monitor 4-1
 Regeneration 4-1
 Access Device 4-1
 System Setup 4-2
Monitor Screen Description 4-2
 Network Status 4-2
 Pump Temperatures 4-3
 Compressor Pressures 4-3
 Show Devices 4-4
 Network Pumps 4-4
 Network Compressors 4-5
 Show Regeneration Setup 4-5
 Rough Map 4-6
 Helium 4-6
 4-6
 Show Helium Maps 4-7
Regeneration Screen Description 4-9
 Regeneration Screen 4-10
 Group Regeneration 4-10
 Regeneration List Verification 4-11
 Regeneration Verification Screen 4-11
 Regeneration Abort 4-12
Access Device Screen Description 4-14
 Network Pumps 4-14
 Network Compressors 4-15
System Setup Screen Description 4-17
 Regeneration Setup 4-17
 Rough Map 4-18
 Password Setup 4-19
 Password Reset 4-20

Communication	4-20
Baud Rate	4-20
Helium	4-21
Choose Helium Map - Pumps	4-21
.....	4-21
Choose Helium Map - Compressors	4-22
Verify Helium Map Setup	4-22
Display Setup	4-23

Section 5 - On-Board IS Cryopump Screen Descriptions

Introduction	5-1
Selecting Screens and Changing Parameters	5-1
Screen Selection	5-1
Changing a Screen Parameter	5-2
MONITOR Function	5-3
Pump State	5-3
Regeneration Information	5-4
Valve Status	5-4
.....	5-4
Temperature Control	5-5
Regeneration Function	5-7
Regeneration Screen	5-8
Start Full Regeneration	5-9
Start Fast Regeneration	5-9
Regeneration Status	5-10
Regeneration Abort	5-10
System Setup Function	5-13
Regeneration Setup	5-13
Purge Setup	5-13
Rough Setup	5-14
Delay Setup	5-15
Security Config	5-16
Change Password	5-16
Communication	5-17
Station ID	5-17
Power Failure	5-18
IS Remote Setup	5-18
Control Function	5-21
Pump Information Screen	5-22

Section 6 - Troubleshooting Procedures

Introduction	6-1
Helix Intercomponent Network	6-1

Appendix A - Customer Support Information

Customer Support Center Locations A-1
Guaranteed Up-Time Support (GUTS) A-1
 Product Information A-1
E-mail A-1

Index

Figures

Figure 1-1: On-Board IS Cryopump System Start-up Flowchart	1-2
Figure 1-2: Typical Helix Intercomponent Network	1-5
Figure 1-3: On-Board IS Cryopump Network Address Settings	1-6
Figure 1-4: On-Board IS-1000 Compressor Network Address Switch	1-6
Figure 1-5: On-Board IS Remote	1-7
Figure 1-6: Network Pumps Screen Example	1-10
Figure 1-7: Network Compressor Screen Example	1-10
Figure 1-8: Pump Address and Temperature Display Example	1-11
Figure 1-9: Compressor Display Example	1-11
Figure 2-1: Rough Map Example	2-1
Figure 2-2: Rough Map Equipment Configuration Example	2-2
Figure 2-3: Helium Map Example	2-3
Figure 2-4: Helium Map Equipment Configuration Example	2-4
Figure 3-1: Regeneration Map Example	3-3
Figure 3-2: Regeneration Map Equipment Configuration Example	3-5
Figure 4-1: On-Board IS Controller Main Screen	4-1
Figure 4-2: Monitor Screen	4-2
Figure 4-3: Network Status Screen	4-2
Figure 4-4: Pump Temperatures Screen	4-3
Figure 4-5: Compressor Pressures Screen	4-3
Figure 4-6: Show Devices Screen	4-4
Figure 4-7: Network Pumps Screen	4-4
Figure 4-8: Network Compressors Screen	4-5
Figure 4-9: Regeneration Screen	4-5
Figure 4-10: Rough Map Screen	4-6
Figure 4-11: Helium Management Screen	4-6
Figure 4-12: Show Helium Maps Screen	4-7
Figure 4-13: Monitor Screens	4-8
Figure 4-14: Regeneration Screen	4-10
Figure 4-15: Group Regeneration Pumps Screen	4-10
Figure 4-16: Start Fast Regeneration Cycle Screen	4-11
Figure 4-17: Regeneration Verification Screen	4-11
Figure 4-18: Regeneration Abort Screen	4-12
Figure 4-19: Regeneration Screens	4-13
Figure 4-20: Choose Device Screen	4-14
Figure 4-21: Network Pump Screen	4-14
Figure 4-22: On-Board IS Pump Information Screen	4-15
Figure 4-23: Network Compressor Screen	4-15
Figure 4-24: On-Board IS-1000 Compressor Information Screen	4-15
Figure 4-25: Access Network Device Screens	4-16
Figure 4-26: System Setup Screen	4-17
Figure 4-27: Regeneration Setup Screen	4-17

Figure 4-28: Rough Map Screen	4-18
Figure 4-29: Verify Rough Map Screen	4-18
Figure 4-30: Password Setup Screen	4-19
Figure 4-31: Entering a Password Screen	4-19
Figure 4-32: Confirm Password Screen	4-19
Figure 4-33: Communication Baud Rate Screen	4-20
Figure 4-34: Choosing Helium Maps Screen	4-21
Figure 4-35: Choosing Helium Maps Screen	4-21
Figure 4-36: Choosing Helium Maps Screen	4-22
Figure 4-37: Verify Helium Map Screen	4-22
Figure 4-38: On-Board IS Remote Setup Screen	4-23
Figure 4-39: System Setup Screens	4-24
Figure 5-1: On-Board IS Remote	5-1
Figure 5-2: Monitor Screen	5-3
Figure 5-3: Pump State Screen	5-3
Figure 5-4: Regeneration Information Screen	5-4
Figure 5-5: Valve Status Screen	5-4
Figure 5-6: Temperature Control Screen	5-5
Figure 5-7: Monitor Function Screens	5-6
Figure 5-8: Regeneration Screen	5-8
Figure 5-9: Start Full Regeneration Cycle Screen	5-9
Figure 5-10: Start Fast Regeneration Cycle Screen	5-9
Figure 5-11: Regeneration Status Screen	5-10
Figure 5-12: Regeneration Abort Screen	5-10
Figure 5-13: Regeneration Function Screens	5-12
Figure 5-14: System Setup Screen	5-13
Figure 5-15: Regeneration Setup Screen	5-13
Figure 5-16: Purge Setup Screen	5-14
Figure 5-17: Rough Setup Screen	5-14
Figure 5-18: Delay Setup Screen	5-15
Figure 5-19: Security Setup Screen	5-16
Figure 5-20: Change Password Screen	5-16
Figure 5-21: Communication Setup Screen	5-17
Figure 5-22: Station ID Setup Screen	5-17
Figure 5-23: Power Failure Screen	5-18
Figure 5-24: Display Setup Screen	5-18
Figure 5-25: System Setup Function Screens	5-20
Figure 5-26: Control Screen	5-21
Figure 5-27: Pump Information Screen	5-22

Tables

Table 3-1: Default Regeneration Parameters	3-1
Table 4-1: IS Remote Setup Parameters	4-23
Table 5-1: Default Regeneration Parameters	5-11
Table 5-2: Purge Setup Parameters	5-14
Table 5-3: Roughing Setup Parameters	5-15
Table 5-4: Delay Setup Parameters	5-15
Table 5-5: Communication Baud Rate Values	5-17
Table 5-6: Power Failure Temperature Ranges	5-18
Table 5-7: Display Setup Parameters	5-19
Table 5-8: Control Parameters	5-21
Table 6-1: Helix Intercomponent Network Troubleshooting Procedures	6-1

Cryopump Safety

Introduction

On-Board products have been designed to provide extremely safe and dependable operation when properly used. Safety precautions must be observed during normal operation and when servicing the On-Board system.

NOTE: NOTE: Read this manual and follow these safety guidelines before installing, operating, or servicing On-Board products.

Warnings

A warning describes safety hazards or unsafe practices which could result in personal injury or loss of life. A warning message is accompanied by a symbol as described in the following paragraphs and is also surrounded by a box to attract your attention.



WARNING

This is a general warning that describes various safety hazards or unsafe practices that could result in personal injury or death.

Cautions

A caution describes safety hazards or unsafe practices which could result in equipment damage.



CAUTION

This is a general caution that describes various safety hazards or unsafe practices that could result in equipment damage.

Toxic, Corrosive, Dangerous Gases, or Liquids



Toxic, corrosive, dangerous gases, or liquids which may be present in an On-Board product could cause severe injury upon contact. Make sure the following precautions are taken when handling toxic, corrosive, or dangerous gases.



1. Always vent toxic, corrosive, dangerous gases, or liquids to a safe location using an inert purge gas.
2. Clearly identify toxic, corrosive, dangerous gases, or liquids on containers used to store or ship equipment after such exposure.

Flammable or Explosive Gases



Flammable or explosive gases which may be present in an On-Board product could cause severe injury if ignited. Make sure the following precautions are taken when handling flammable or explosive gases:



1. Always vent flammable or explosive gases to a safe location using an inert purge gas.
2. Do not install a hot filament type vacuum gauge on the high vacuum side of the isolation valve. This could be an ignition source of flammable gases in On-Board products.

High Voltage



High voltage electric shock can cause severe injury or loss of life. Take the following precautions to prevent high voltage risks:

1. Disconnect the high vacuum pump system from all power sources before making electrical connections between system components or before performing troubleshooting and maintenance procedures.

High Gas Pressure



High gas pressure may be present within high vacuum pump systems and can cause severe injury from propelled particles or parts.

1. Do not modify or remove the pressure relief valves, either on the On-Board pump or within the helium compressor.
2. Always depressurize the adsorber to atmospheric pressure before disposing.

3. Always bleed the helium charge down to atmospheric pressure before servicing or disassembling the self sealing couplings.

Cryopump Oxygen Procedures



WARNING

Combustion supported by oxygen in the cryopump could cause severe injury when oxygen is used as a process gas. Special precautions described in the following text should be taken.

When oxygen is used as a process gas, the following precautions should be taken:

1. Insure that there are no sources of ignition (e.g. hot filament vacuum gauges) on the cryopump side of the high vacuum valve operating during the warming or venting of the cryopump.
2. Perform inert gas purge regeneration cycles at flow rates recommended for cryopumps.
3. Regenerate as frequently as practical to minimize the amount of oxidizer present in the cryopump.
4. It is standard practice in the vacuum industry that any system exposed to richer-than-air oxygen levels should be prepared for oxygen service per the manufacturer's recommendations, including use of oxygen service lubricating oils in roughing pumps.



WARNING

Explosion occurring from ozone in the cryopump could cause severe injury. Ozone can be present as a by product of oxygen processes. If ozone is present, special precautions described in the following text must be taken.

Ozone may be unknowingly produced in an ionizing process (e.g. sputtering, etching, glow discharge). Explosive conditions may exist if ozone is present, especially during the warming of the cryopump. Signs of ozone's presence are:

1. Crackling, popping sounds (as in electrical arcing) occurring within the first few minutes of a regeneration cycle.
2. Gas venting from the cryopump during regeneration may have a

pungent smell, similar to that present in an arc welding operation or after an electrical storm.

NOTE: NOTE: *A change in process may increase the amount of ozone present.*

If ozone is present, the following precautions must be taken:

1. All of the above oxygen precautions must be followed. The required regeneration frequency is dependent upon flow and process conditions. Daily regeneration may be required. Call CTI-CRYOGENICS for assistance.
2. Reduce the oxygen mixture to the lowest level the process will allow.

Section 1 - Getting Started

Introduction

The On-Board *IS* Cryopump System Operation Guide will help you to initialize the On-Board *IS* Cryopump System after all system components have been installed.

By following the information in this guide, you will go through the appropriate steps to make sure the On-Board *IS* Cryopump System parameters have been properly set and the system is initialized properly.

The flowchart in [Figure 1-1](#) lists the steps required to verify proper installation of On-Board *IS* Cryopump components and references procedures throughout this guide for system setup.

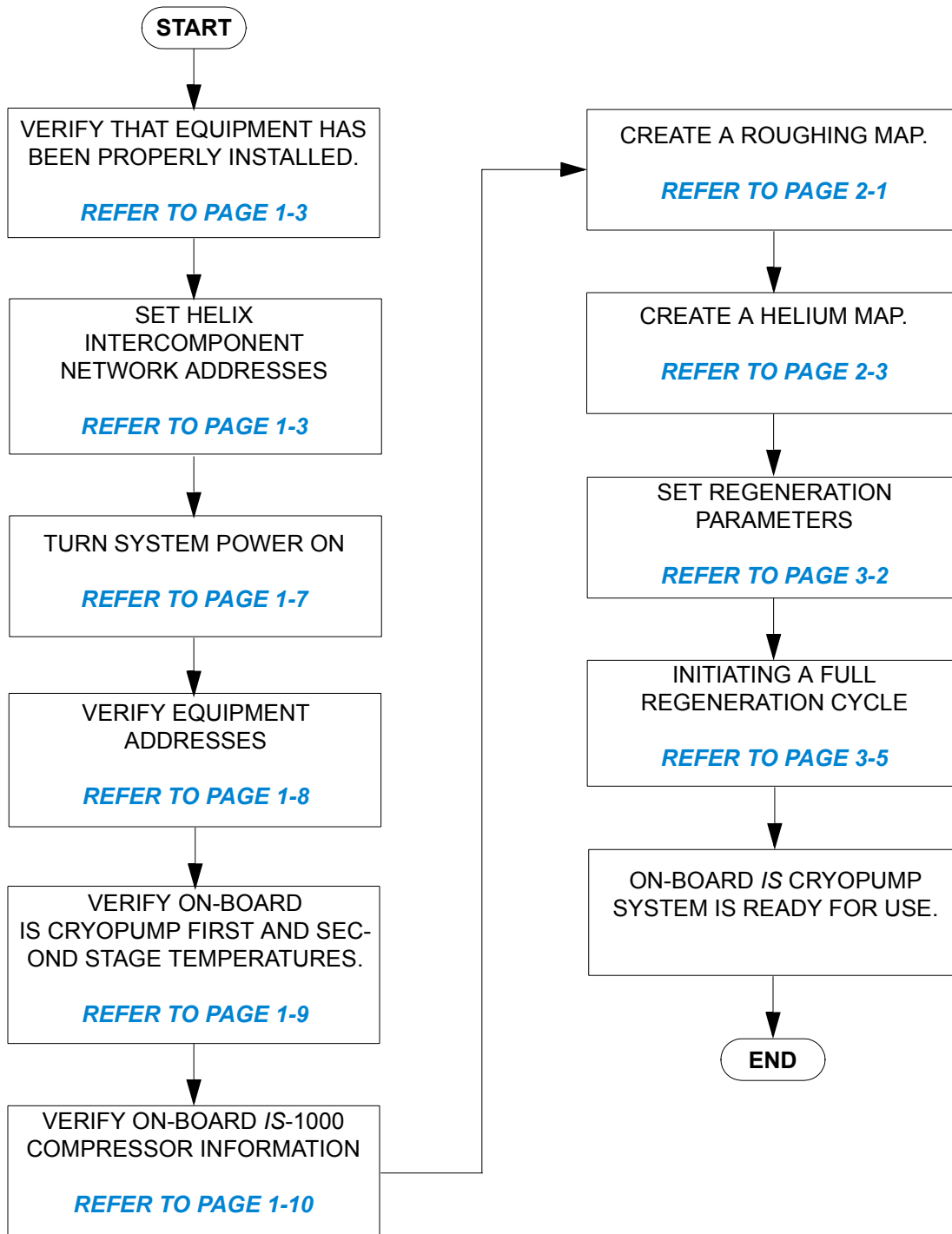

Figure 1-1: On-Board IS Cryopump System Start-up Flowchart

Equipment Installation Verification

NOTE: It is important to make sure that all On-Board IS Cryopump System components have been installed and are properly connected to the Helix Intercomponent Network before process tool operation can begin.

On-Board IS Cryopumps

Make sure the On-Board IS Cryopumps have been installed according to the directions found in the appropriate **On-Board IS Cryopump Quick Installation Guide**, included with each Cryopump.

On-Board IS-1000 Compressor

Make sure the On-Board IS-1000 Compressors have been installed according to the directions found in the **On-Board IS-1000 Compressor Quick Installation Guide**, Helix P/N 8040645 included with each Compressor.

On-Board IS Controller

Make sure the On-Board IS Controller has been installed according to the directions found in either the *Rack Mount* or *Pump Mount* **On-Board IS Controller Quick Installation Guide** included with the Controller.

On-Board IS Remote

Make sure the On-Board IS Remote has been installed according to the directions found in the **On-Board IS Remote Quick Installation Guide**, Helix P/N 8040664 included with the Remote.

Helix Intercomponent Network Address Settings

The Helix Intercomponent Network contains three channels; A, B and C. On-Board IS Cryopumps are connected to Channels A and B.

On-Board IS-1000 Compressors are connected to Channel C. Refer to **Figure 1-2** for an example of an On-Board IS Cryopump System.

Once the On-Board IS Cryopumps, On-Board IS-1000 Compressors and On-Board IS Controller have been properly installed, the respective network address for each system component must be set.

NOTE: Make sure a network terminator has been installed in the network cable connector on the last On-Board IS Cryopump or On-Board IS-1000 Compressor on each network channel. Otherwise, network communication

will fail.

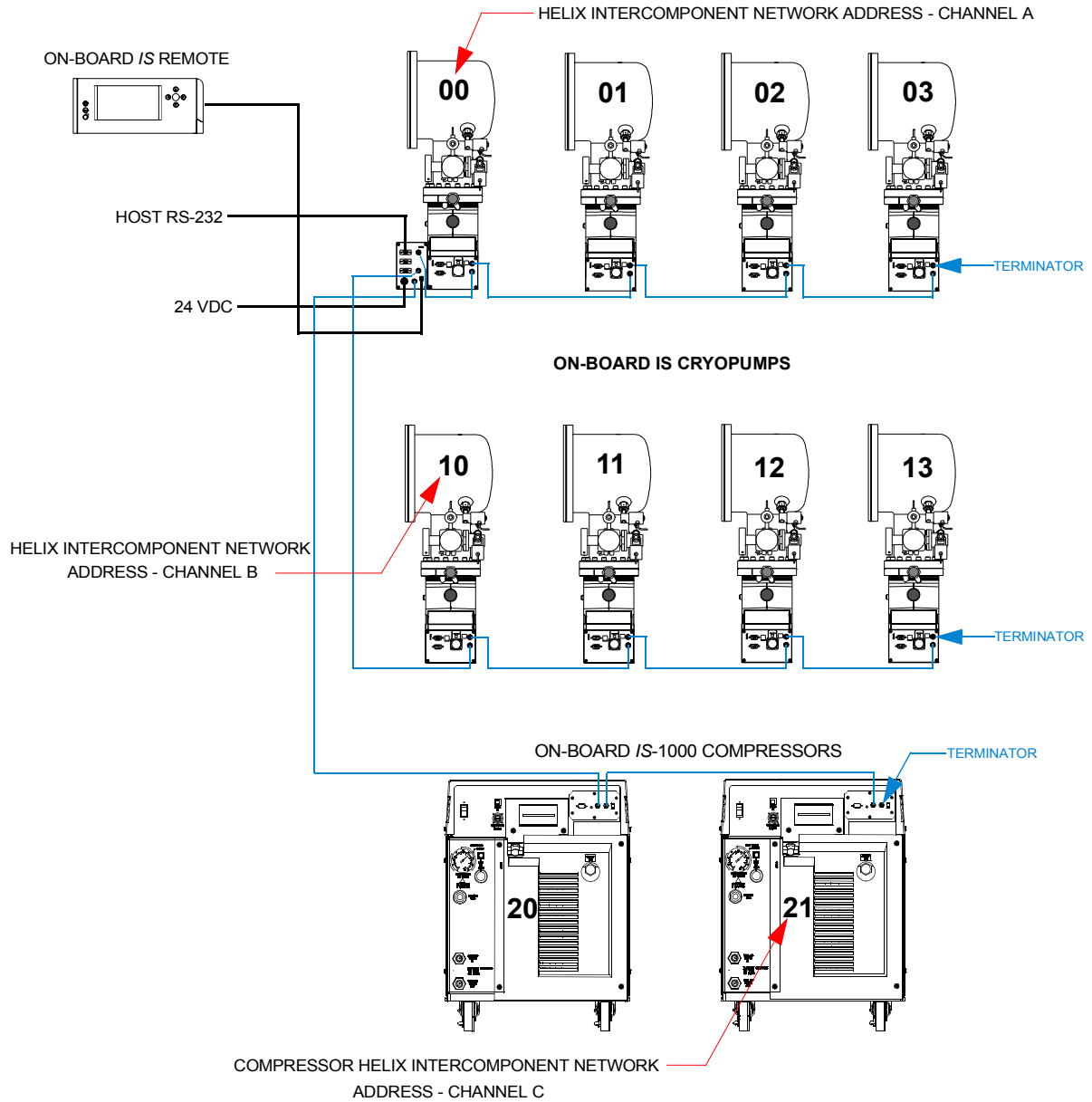

Figure 1-2: Typical Helix Intercomponent Network

On-Board IS Cryopump Addresses

1. Set the address switch for each On-Board IS Cryopump on channel A to the appropriate network address as shown in Figure 1-3.
2. Set the address switch for each On-Board IS Cryopump on channel B to the appropriate network address as shown in Figure 1-3.

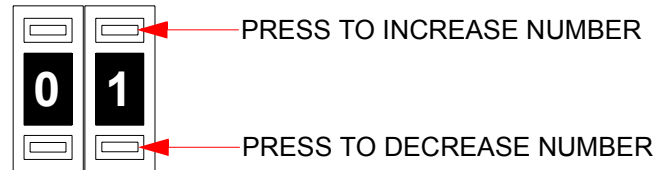
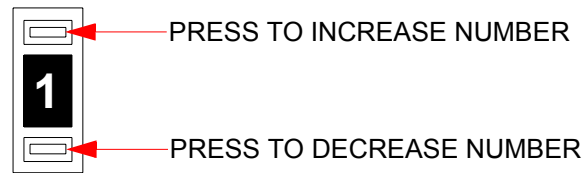

Figure 1-3: On-Board IS Cryopump Network Address Settings

On-Board IS-1000 Compressor Addresses

1. Set the address switch for each On-Board IS-1000 Compressor on channel C to the appropriate network address as shown in Figure 1-4.



NOTE: The On-Board IS-1000 Compressor Address switch settings (0 - 9) are converted by the On-Board IS Controller and displayed as (20 - 29) on On-Board IS Remote.

Figure 1-4: On-Board IS-1000 Compressor Network Address Switch

Selecting Screens and Changing Parameters

Regardless of the screen, the method by which screens are selected and values are changed is the same. Use the following procedures to select screens and change values on the On-Board *IS* Remote shown in Figure 1-5.

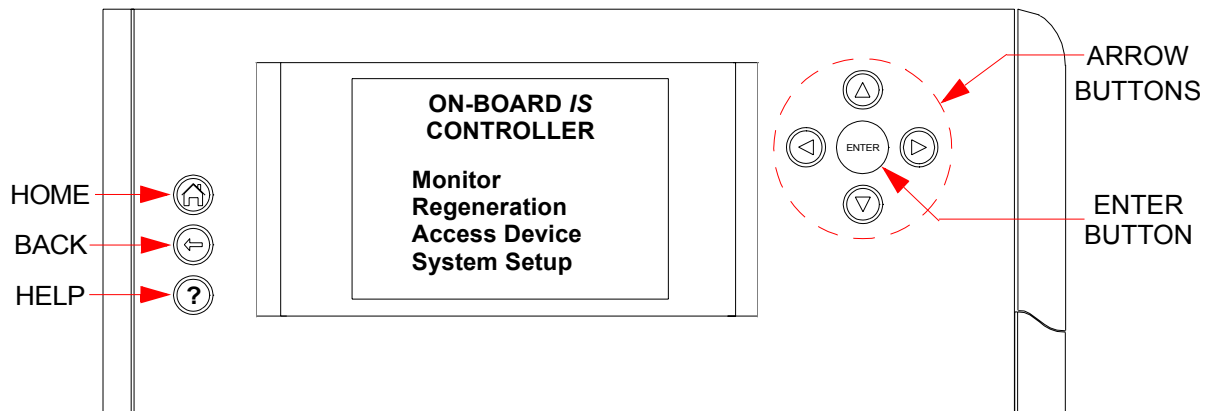

Figure 1-5: On-Board *IS* Remote

Screen Selection

1. Using the arrow buttons, select the desired screen to be viewed.
2. Press the **ENTER** button. The selected screen will appear.
3. Use the arrow buttons to move the cursor to the selected screen item.
4. Press the **ENTER** button. The selected screen appears.

Changing a Screen Parameter

1. Using the arrow buttons, select the desired screen to be viewed.
2. Press the **ENTER** button. The selected screen will appear.
3. Use the **LEFT/RIGHT** arrow buttons to move the cursor under the parameter to be changed.
4. Press the **ENTER** button. The parameter to be changed will be underlined.
5. Use the **UP/DOWN** arrow buttons to change the value.
6. Press the **ENTER** button. The parameter will be changed to the new value.

NOTE: When the Remote Display is idle for 15 minutes, a screen saver

will be activated and will dim the display to its lowest level and scroll from right to left across the screen. Pressing any one of the buttons on the remote display will turn the screen saver off and return the screen to its normal brightness.

System Power

Turning Power On

Once all Helix Intercomponent Network address settings have been set, turn power ON to the On-Board *IS* Cryopump system as follows:

1. Close all process chamber Hi-Vac valves.
2. Set the On-Board *IS*-1000 Compressor System Circuit Breaker to the ON (UP) position.
3. Set the On-Board *IS*-1000 Compressor Control Circuit Breaker to the ON (UP) position.
4. Set the power switch on the front panel of the On-Board *IS*-1000 Compressors to the ON position.
5. Set the local circuit breaker that supplies power to each On-Board *IS* Cryopump to the ON position.
6. Set the power switch on the 24 VDC On-Board *IS* Controller power supply to the ON position.
7. Proceed with [Selecting Screens and Changing Parameters](#).

Turning Power Off



CAUTION

A Full regeneration cycle must be performed before shutting power off to the On-Board *IS* Cryopump system to prevent pump contamination.

1. Close all Hi-Vac valves between the On-Board *IS* Cryopumps and the vacuum system.
2. Using the arrow buttons, select **REGENERATION** from the On-Board *IS* Controller screen and press **ENTER**. The Regeneration screen will be displayed.
3. Using the arrow buttons, select **START** from the Regeneration screen.
4. Press the **ENTER** button. The Choose Regen Pumps screen will be

- displayed.
5. Choose all pumps in the full regeneration cycle as follows:
 - a. Using the arrow buttons, select each pump to be included in the full regeneration cycle.
 - b. Press **ENTER**. The box will become highlighted.
 - c. Repeat steps a - b for each pump.
 - d. Press **ENTER**. The List to Regen screen appears.
 6. Select **FULL** and press **ENTER**.
 7. Select **YES** from the Start Regen screen. A full regeneration cycle will begin.
 8. Once the **2nd Stage** temperature has reached 310K, use the arrow buttons and select **ABORT** from the Regeneration Status screen.
 9. Press the **ENTER**.
 10. Select **YES** from the Abort Regeneration screen and press **ENTER**. The full regeneration cycle will be aborted.
 11. Turn the compressor ON/OFF switch to the OFF position.
 12. Turn power OFF to each On-Board *IS* Cryopump.
 13. Turn the roughing pump OFF.

Equipment Address Verification

Once the address settings have been set and power has been turned ON, verify the presence of each On-Board *IS* Cryopump and On-Board *IS*-1000 Compressor on the Helix Intercomponent Network by performing the following steps from the On-Board *IS* Remote.

Helix Intercomponent Network Addresses

Verify that each On-Board *IS* Cryopump can be displayed as follows:

1. Select **MONITOR** and press **ENTER**. The Monitor Network screen appears.
2. Select **SHOW DEVICES** and press **ENTER**. The Network Devices screen appears.
3. Verify the number of actual pumps and compressors on the network with the number on the Network Devices screen.
4. Select **PUMPS** and press **ENTER**. The Network Pumps screen appears. Verify that each On-Board *IS* Cryopump is displayed as shown in Figure 1-6.

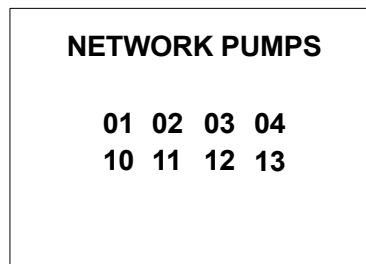

Figure 1-6: Network Pumps Screen Example

5. Press **BACK**. The Network Devices screen appears.
6. Select **COMPRESSORS**.
7. Press **ENTER**. The Network Compressor screen appears. Verify that each On-Board *IS-1000* Compressor is displayed as shown in Figure 1-7.

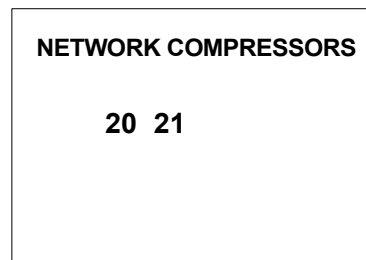

Figure 1-7: Network Compressor Screen Example

***NOTE:** If an On-Board *IS* Cryopump or On-Board *IS-1000* Compressor is not listed on the screen, make sure power has been turned *ON* and check all Helix Intercomponent Network cable connections. Make sure a terminator has been installed on the last Cryopump and Compressor on each network channel.*

On-Board *IS* Cryopump Temperatures

Verify that first and second stage temperatures for each On-Board *IS* Cryopump are displayed as follows:

1. Select **MONITOR** then press **ENTER**. The Monitor Network screen appears.
2. Select **NETWORK STATUS** then press **ENTER**. The Network Status screen appears.
3. Select **PUMPS** then press **ENTER**. The Pump Temperature screen

appears and the first and second stage temperatures are displayed as shown in Figure 1-8.

PUMP TEMPS ID T1/T2 (K)			
01	290/295	02	289/291
03	289/291	04	290/294
10	287/290	11	289/290
12	290/289	13	288/289

Figure 1-8: Pump Address and Temperature Display Example

For example: *01 290/295* indicates that pump 01 has a first stage room temperature of 290K and second stage room temperature of 295K.

On-Board IS-1000 Compressor Information

Verify On-Board IS-1000 Compressor helium pressure, water temperature and operating hours for each compressor are displayed as follows:

1. Select **ACCESS DEVICE** then press **ENTER**. The Access Network Device screen appears.
2. Select **COMPRESSORS** and press **ENTER**. The Network Compressors screen appears.
3. Select a compressor number from the Network Compressor Screen and press **ENTER**. The Compressor screen appears.
4. Verify that the helium supply and return pressure, delta pressure, water in/out temperature, and operating hours information is displayed as shown in Figure 1-9.

COMPRESSOR 20	
Supply Pressure	378
Return Pressure	179
Delta Pressure	199
Water In (F)	77
Water Out (F)	93
Operating Hours	462

Figure 1-9: Compressor Display Example

Password Setup

NOTE: This procedure establishes password protection for the On-Board IS Controller.

If desired, a numeric password can be created to prevent On-Board IS Cryopump system parameters from being changed by unauthorized users. Use the following procedure to establish a password.

1. Select **SYSTEM SETUP** from the Helix Intercomponent Network Controller screen and press **ENTER**. The System Setup screen appears.
2. Select **PASSWORD** and press **ENTER**. The Password Setup screen appears.
3. Select **PROTECTION** then press **ENTER**. The cursor moves under **OFF**.
4. Use the **UP/DOWN** arrow buttons to change the value from *OFF* to *ON*.
5. Press the **ENTER** button. The password protection parameter will be changed to *ON* and the password screen appears with the cursor located in the first number field of the password.
6. Enter password number as follows:
 - a. Use the **UP/DOWN** arrow buttons to change the first digit to the desired value.
 - b. Press the **RIGHT** arrow button to move the cursor to the next digit.
 - c. Use the **UP/DOWN** arrow buttons to change the number to the desired value.
 - d. Repeat steps b - c for each digit in the password.

NOTE: The digits will change to an asterisk once the right arrow button is pressed to protect the password.

- e. Press **ENTER**. The Confirm Password screen appears.
7. Repeat step 6 to confirm the password. Once you press **ENTER**, password protection is enabled.

What's Next?

Refer to [Section 2 - Creating Rough and Helium Maps](#) to establish rough and helium maps for the On-Board IS Cryopump System.

What's Next?

Section 2 - Creating Rough and Helium Maps

Introduction

Section 2 provides you with information to Rough maps and Helium maps. These maps must be established to ensure optimum On-Board IS Cryopump performance.

Roughing Maps

A *Roughing Map* is used for multiple pump systems that share a roughing pump through a roughing manifold. Roughing map examples are shown in Figure 2-1 and the equipment configuration for the map is shown in [Figure 2-2](#).



Figure 2-1: Rough Map Example

A roughing map keeps track of which pumps are on which roughing manifold. All On-Board IS Cryopumps that are connected to a single roughing manifold are in the same map. If your system has more than one roughing manifold, then you can have more than one roughing map. It is possible to have up to five roughing maps in a multi-pump On-Board IS System. When the On-Board IS Cryopumps are properly mapped, the On-Board IS Controller will coordinate the use of the roughing valves for both Full regeneration and FastRegen cycles.

Roughing Maps

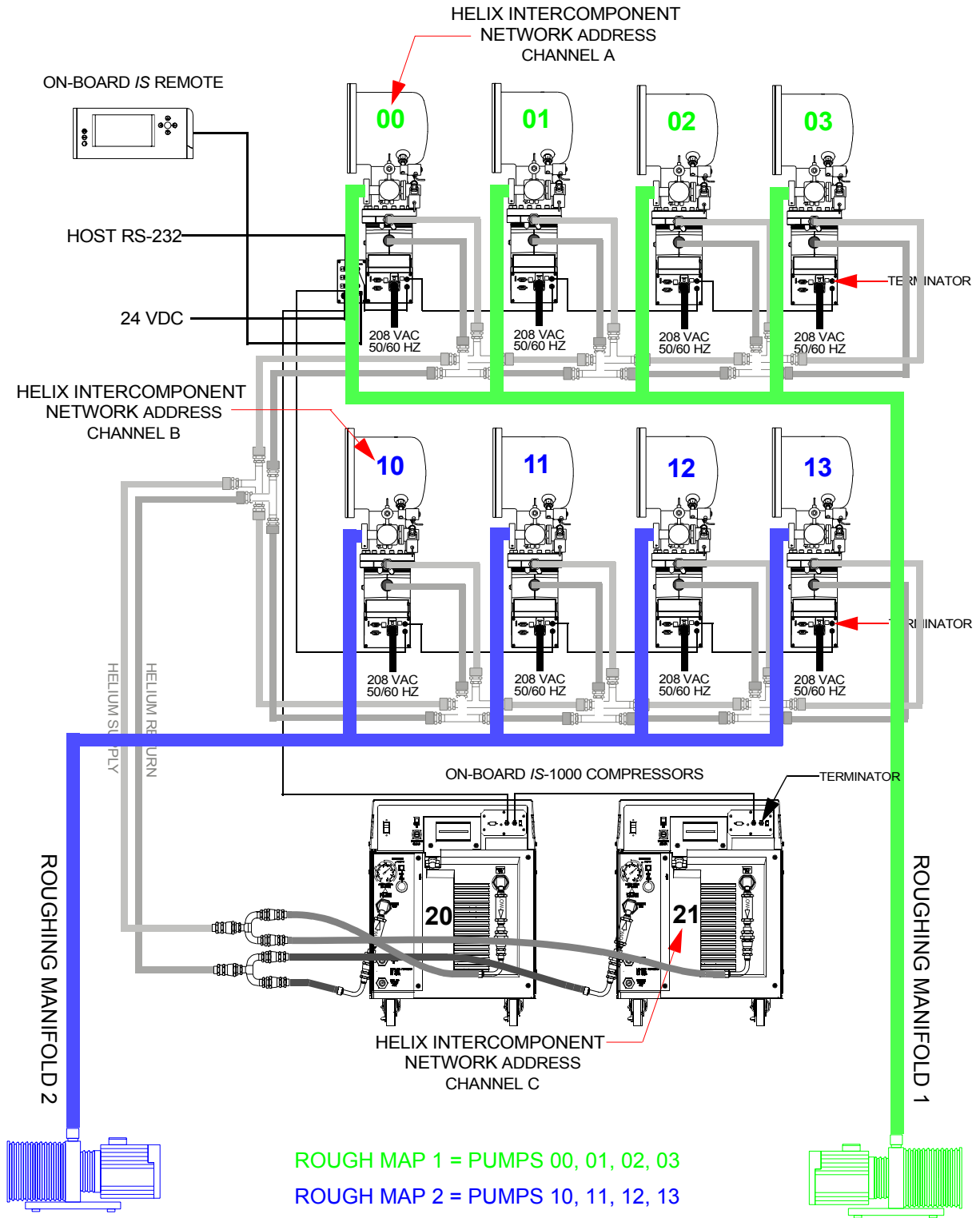

Figure 2-2: Rough Map Equipment Configuration Example

Creating a Roughing Map

1. Using the arrow buttons, select **SYSTEM SETUP** from the On-Board *IS* Controller screen and press **ENTER**.
2. Select **REGENERATION** from the System Setup screen and press Enter.
3. Select **ROUGH MAP** from the Regeneration Setup screen and press **ENTER**.
4. Using the arrow buttons, change the map number to the appropriate value and press **ENTER**.
5. Choose the pumps to be included in the helium map as follows:
 - a. Using the arrow buttons, select a pump to be included in the helium map.
 - b. Press **ENTER**. The box will become highlighted.
 - c. Repeat steps a - b for each pump in the map.
 - d. Press **ENTER**. The Verify Rough Map screen appears.
6. Verify that the rough map information is correct. If the information is correct, press **ENTER** to create the rough map. If the information is *not* correct, press **BACK** to the appropriate screen and change the rough map parameters.

Helium Maps

A *Helium Map* establishes which On-Board *IS* Cryopumps are connected to the On-Board *IS*-1000 Compressor for each process tool. A Helium map example is shown in Figure 2-3 and the equipment configuration for the map is shown in [Figure 2-4](#).

HELIUM MAP 1			
Pumps/Compressors:			
00	01	02	03
10	11	12	13
20	21		

Figure 2-3: Helium Map Example

NOTE: A *Helium Map* must be created for each process tool to allow the On-Board *IS* Controller to optimize the flow of helium to all On-Board *IS* Cryopumps.

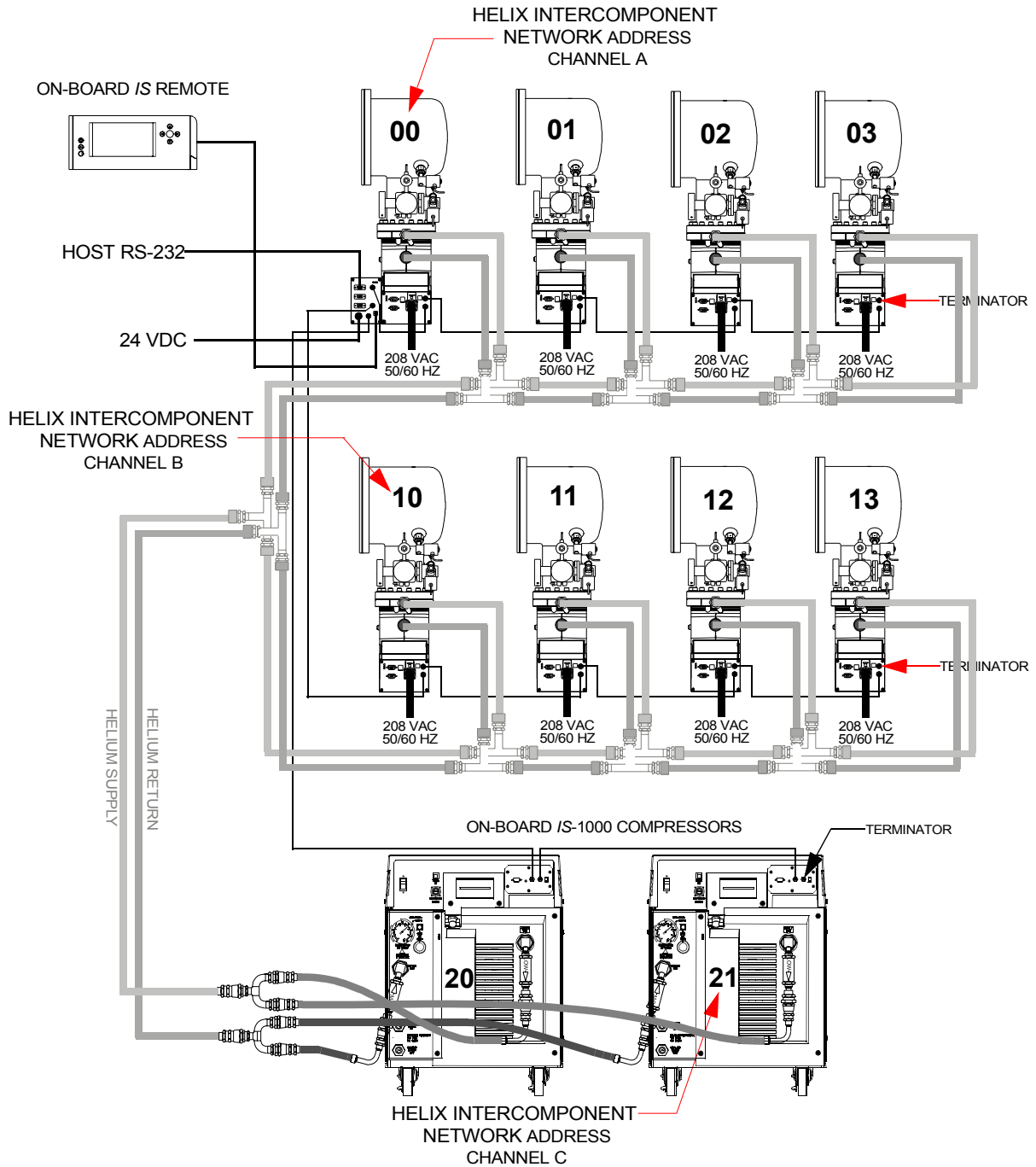

Figure 2-4: Helium Map Equipment Configuration Example

Creating a Helium Map

1. Using the arrow buttons, select **SYSTEM SETUP** from the On-Board *IS* Controller screen and press **ENTER**.
2. Select **HELIUM** from the System Setup screen and press **ENTER**.
3. Using the arrow buttons, select the helium map number and press **ENTER**.
4. Choose the pumps to be included in the helium map as follows:
 - a. Using the arrow buttons, select a pump to be included in the helium map.
 - b. Press **ENTER**. The box will become highlighted.
 - c. Repeat steps a - b for each pump in the map.
 - d. Press **ENTER**. The Choose Compressors screen appears.
5. Choose the compressors to be included in the map as follows:
 - a. Using the arrow buttons, select a compressor to be included in the helium map.
 - b. Press **ENTER**. The box will become highlighted.
 - c. Repeat steps a - b for each compressor in the map.
 - d. Press **ENTER**. The Verify Helium Map screen appears.
6. Verify that the helium map information is correct. If the information is correct, press **ENTER** to create the helium map. If the information is *not* correct, press **BACK** to the appropriate screen and change the helium map parameters.

What's Next?

Refer to [Section 3 - Regeneration](#) to establish regeneration parameters, create a regeneration map and initiate a full regeneration cycle for the On-Board *IS* Cryopump System.

Section 3 - Regeneration

Introduction

The On-Board *IS* Cryopump Module contains factory set regeneration parameters which are listed in Table 3-1. If the default regeneration parameters need to be changed for your process, then the Remote Display must be connected to each On-Board *IS* Cryopump and the regeneration parameters can be changed.

Once the regeneration parameters have been established, a Full regeneration cycle is required to cool the On-Board *IS* Cryopumps to operating temperature.

Table 3-1: Default Regeneration Parameters

Regeneration Parameter	Default Value	Range of Values	Fast	Full
Extended Purge	1 minute	0 - 9999 minutes		✓
Repurge	15 minutes	0 - 9999 minutes		✓
Repurge Cycles	15	0 - 20 cycles		✓
Base Pressure	50 microns	25 - 200 microns	✓	✓
Rate-of-Rise (ROR)	10 microns/minute	1 -100 microns/minute		✓
ROR Cycles	20	0 - 40 cycles		✓
Rough Test	150 seconds	10 - 999 seconds	✓	
Rough Coordination	OFF	ON/OFF	✓	✓
Start Delay	0	0 - 999.9 hours	✓	✓
Restart Delay	0	0 - 999.9 hours		✓
Power Fail Recovery	OFF	ON/OFF/COOL	✓	✓
Power Fail Recovery Temperature	25K	0 - 80K	✓	✓

NOTE: The check mark (✓) in the Fast and Full columns in Table 3-1 indicates whether the regeneration parameters are used during the Fast and/or Full regeneration cycles.

Setting Regeneration Parameters

Change the Regeneration parameters on each On-Board *IS* Cryopump as follows:

NOTE: Refer to the [Regeneration Function](#) in Section 5 for more information on Regeneration screen parameters.

1. Disconnect the On-Board *IS* Remote from the On-Board *IS* Controller and connect it to **REMOTE DISPLAY** connector on the first On-Board *IS* Cryopump. Wait for the Cryopump Controller screen to appear.
2. Select **SYSTEM SETUP** from the On-Board *IS* Cryopump Controller screen and press **ENTER**. The System Setup screen appears.
3. Select **REGENERATION** and press **ENTER**. The Regeneration Setup screen appears.
4. Select **PURGE** then press **ENTER**. The Purge Setup screen appears.
5. Set the Purge Setup values as follows:
 - a. Use the arrow buttons to move the cursor under the parameter to be changed.
 - b. Press the **ENTER** button. The parameter to be changed will be underlined.
 - c. Use the arrow buttons to change the value.
 - d. Press the **ENTER** button. The parameter will be changed to the new value.
6. Press **BACK**. The Regeneration Setup screen appears.
7. Select **ROUGHING** then press **ENTER**. The Roughing Setup screen appears.
 - a. Use the arrow buttons to move the cursor under the parameter to be changed.
 - b. Press the **ENTER** button. The parameter to be changed will be underlined.
 - c. Use the arrow buttons to change the value.
 - d. Press the **ENTER** button. The parameter will be changed to the new value.
8. Press **BACK**. The Regeneration Setup screen appears.
9. Select **DELAY** then press **ENTER**. The Delay Setup screen appears.

- a. Use the arrow buttons to move the cursor under the parameter to be changed.
- b. Press the **ENTER** button. The parameter to be changed will be underlined.
- c. Use the arrow buttons to change the value.
- d. Press the **ENTER** button. The parameter will be changed to the new value.

Regeneration Maps

A *Regeneration Map* is created when you wish to regenerate a group of On-Board *IS* Cryopumps together. A Regeneration map example is shown in Figure 3-1 and the equipment configuration for the map is shown in Figure 3-2.

NOTE: *The Cryopumps in the regeneration map may or may not be in the same roughing map.*

<p style="text-align: center;">LIST TO REGEN</p> <p style="text-align: center;">01 02 12 13</p> <p style="text-align: center;">START FAST REGEN START FULL REGEN</p>
--

Figure 3-1: Regeneration Map Example

An On-Board *IS* Cryopump System can have up to five Regeneration Groups. When the regeneration is started, the On-Board *IS* Controller will coordinate the use of the roughing manifold for each Regeneration Group and Roughing Map.

There is a special requirement for a FastRegen cycle. This requirement is that a On-Board *IS* Cryopump in the FastRegen process must have use of the roughing valve at specific times. Because of this requirement, if there is more than one On-Board *IS* Cryopump on a roughing manifold and they are to be put through a FastRegen, then they must all be started and run at the same time so that they can all be roughed at the same time. This also means that if there is a On-Board *IS* Cryopump in the process of FastRegen cycle, then no other Cryopump on that roughing manifold can start a

FastRegen cycle until that Cryopump is finished.

This is not true for Full regeneration. Full regeneration cycles can be started and stopped at any time, even if another pump on the same roughing map is in regeneration.

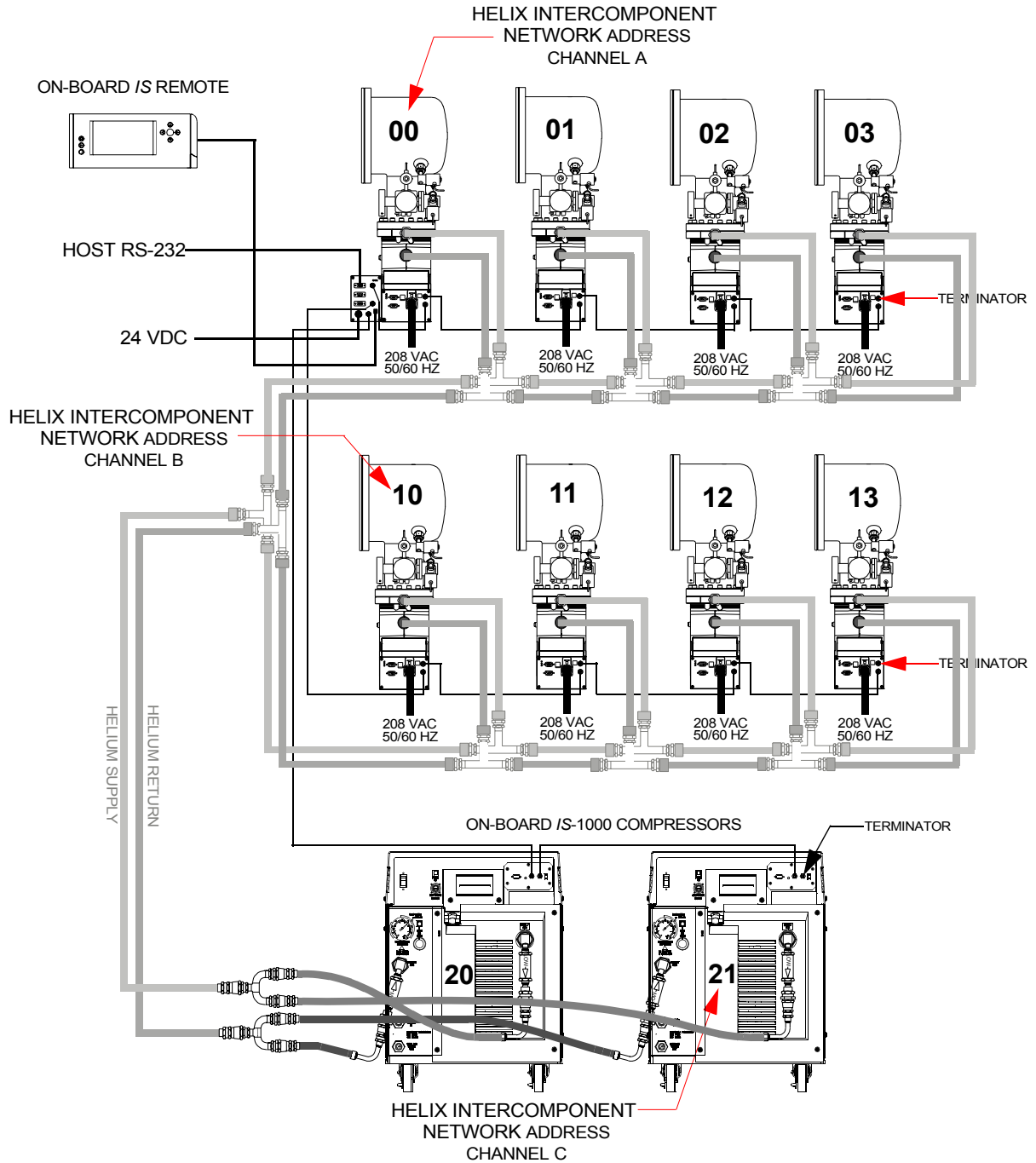

Figure 3-2: Regeneration Map Equipment Configuration Example

Initiating a Full Regeneration Cycle

Once all regeneration parameters have been set, you must run a full regeneration cycle to cool the On-Board *IS* Cryopumps to operating temperature.

1. Close all process tool chamber gate valves.
2. Using the arrow buttons, select **REGENERATION** from the On-Board *IS* Controller screen and press **ENTER**. The Regeneration screen will be displayed.
3. Using the arrow buttons, select **START** from the Regeneration screen.
4. Press the **ENTER** button. The Choose Regen Pumps screen will be displayed.
5. Choose the pumps to be included in the full regeneration cycle as follows:
 - a. Using the arrow buttons, select a pump to be included in the full regeneration cycle.
 - b. Press **ENTER**. The box will become highlighted.
 - c. Repeat steps a - b for each pump in the full regeneration cycle.
 - d. Press **ENTER**. The List to Regen screen appears.
6. Select **FULL** and press **ENTER**.
7. Select **YES** from the Start Regen screen. A full regeneration cycle will begin.

What's Next?

Once the full regeneration cycle has been completed, the On-Board *IS* Cryopump system is ready for process tool operation.

Section 4 - On-Board *IS* Controller Screen Descriptions

Introduction

The On-Board *IS* Controller Main screen, shown in Figure 4-1, allows the user to select various software functions when the On-Board *IS* Remote is connected to the On-Board *IS* Controller.



Figure 4-1: On-Board *IS* Controller Main Screen

Monitor

The Monitor Function allows the user to view the status of network data and configurations. Refer to Monitor Function within this section for more information.

Regeneration

The Regeneration Function allows the user to establish regeneration cycle information on user selected On-Board *IS* Cryopumps. Refer to Regeneration Function within this section for more information.

Access Device

The Access Device function allows the user to start a session with a

On-Board *IS* Cryopump or other device on the network. Refer to Access Device Function within this section for more information.

System Setup

The System Setup Function allows the user to change and display the configuration of the On-Board *IS* Controller. Refer to System Setup Function within this section for more information.

Monitor Screen Description

The Monitor Network screen allows you to observe the cryopump state, regeneration information, valve status and temperature control information of the On-Board *IS* Cryopump.

NOTE: Screen parameters cannot be changed while using the MONITOR function.

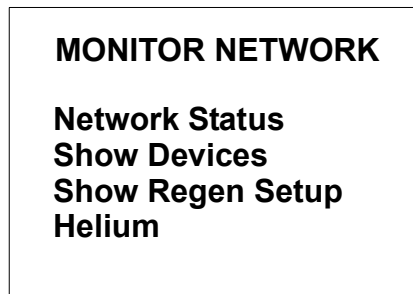

Figure 4-2: Monitor Screen

Network Status

The Network Status screen allows users to monitor pumps and compressors on the network.

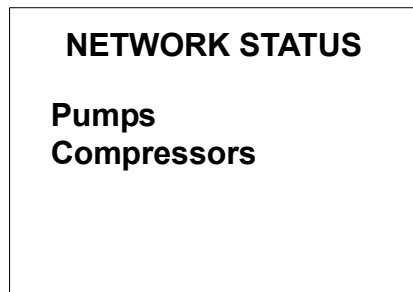

Figure 4-3: Network Status Screen

Pump Temperatures

The Pump Temperatures screen displays the first and second stage cryopump temperatures for all pumps on the network. Use the down arrow button to scroll down the pump list if required.

NOTE: If an On-Board IS Waterpump is on the network, the temperature will be displayed as NA.

PUMP TEMPS ID T1/T2 (K)			
01	35/12	02	120/108
03	150/84	04	50/37
05	43/40	06	123/75
07	99/8		

Figure 4-4: Pump Temperatures Screen

Compressor Pressures

The Compressor Pressures screen displays the Supply and change in pressure for all compressors on the network.

IS COMPRESSORS (SupplyP/DeltaP)	
20	390/205

Figure 4-5: Compressor Pressures Screen

Show Devices

The Network Devices screen displays a list of equipment types and quantity of equipment on the network.

NETWORK DEVICES	
Pumps	12
Compressors	6

Figure 4-6: Show Devices Screen

Network Pumps

The Network Pumps screen identifies all On-Board *IS* Cryopumps on the network.

NETWORK PUMPS				
00	01	02	03	04
05	06	09	12	17
18	19			

Figure 4-7: Network Pumps Screen

Network Compressors

The Network Compressors screen identifies all On-Board *IS-1000* Compressors on the network.

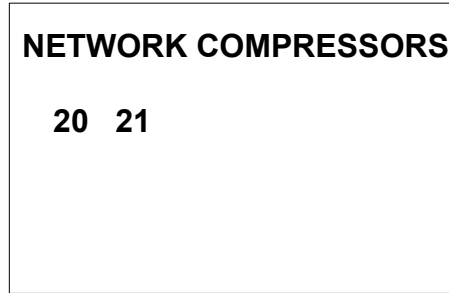

Figure 4-8: Network Compressors Screen

Show Regeneration Setup

The Regeneration screen allows a user to turn rough valve coordination and power failure recovery ON or OFF and to review roughing maps.

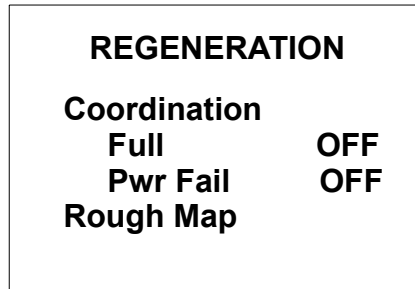

Figure 4-9: Regeneration Screen

Rough Map

The Rough Map screen displays the first of 5 rough maps. To view additional rough maps, select NEXT MAP.

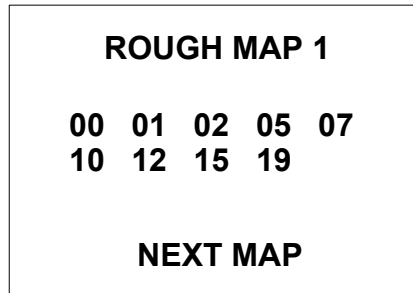

Figure 4-10: Rough Map Screen

Helium

The Helium Management screen allows a user to review helium maps.

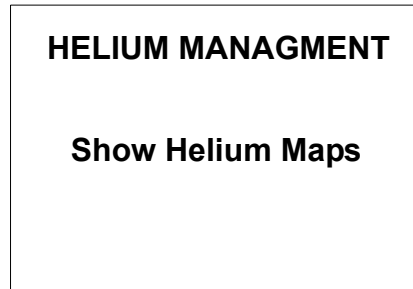

Figure 4-11: Helium Management Screen

Show Helium Maps

The Show Helium Maps screen displays helium maps 1 through 5. To view additional helium maps, select NEXT MAP.

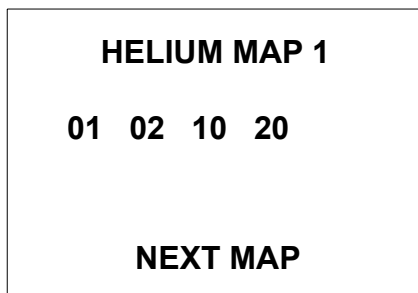

Figure 4-12: Show Helium Maps Screen

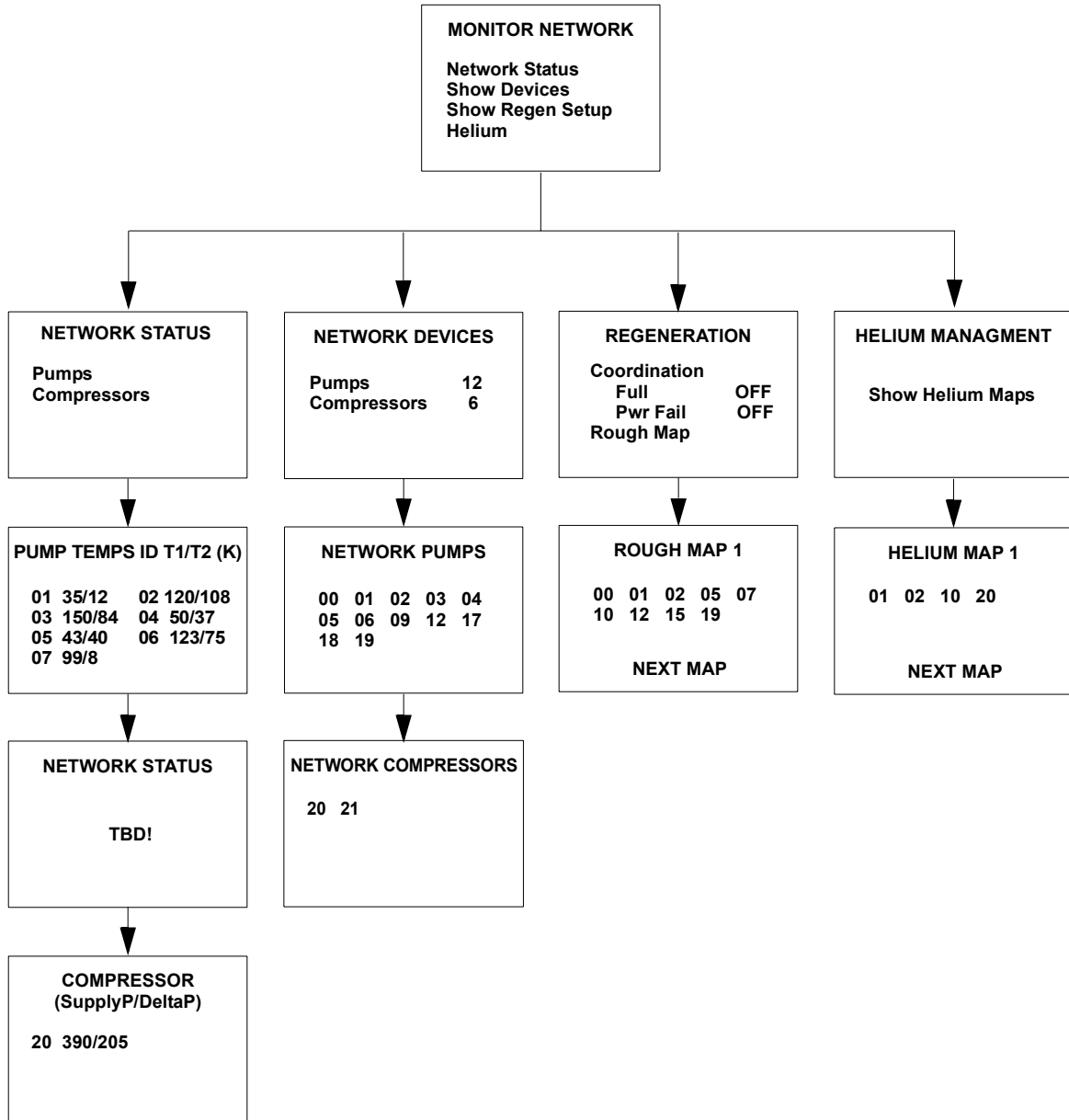

Figure 4-13: Monitor Screens

Regeneration Screen Description

The Regeneration function of the On-Board *IS* Controller allows you to initiate a Full or Fast regeneration cycle on your cryopump. Once initiated, the On-Board *IS* System automatically sequences your pump through the various phases of the regeneration cycle.

A Full regeneration cycle allows the cryopump to warm-up to room temperature so that both gases and water vapor collected on the arrays are purged from the pump. Once the contaminants are purged, the cryopump becomes cold again.

In many cases, there is little water pumped and so it is not necessary to warm the pump to room temperature. If the pump is primarily filled with such gases as argon, nitrogen or hydrogen, then the pump can be regenerated using a Fast Regeneration cycle. A Fast regeneration cycle only warms the cryopump enough to release the gases condensed on the arrays and trapped within the charcoal. This allows the regeneration cycle to be completed in less than an hour in many cases.

One of the key process steps in a Fast regeneration cycle is the removal of the condensed gas by means of the roughing pump. It is important that the condensed gas be removed quickly as the pump warms up, and that a certain minimum base pressure in the cryopump be achieved quickly. Because of these requirements, it is necessary for cryopumps that share a common roughing pump be coordinated. That is, the start of regeneration, the opening and closing of the roughing valves and the purge valves on multi-pump On-Board *IS* Cryopump systems must happen at very specific times and in unison. These are coordinated by the On-Board *IS* Controller. The roughing valves are coordinated for both Fast and Full regeneration cycles although for different reasons.

Typically, regeneration is a function that is part of overall periodic maintenance for a cryopump system: frequency is dependent upon your particular pump application, but the cycle can be manually started at any time.

The Regeneration program incorporates a number of parameters that are preset at the factory, such as RATE-OF-RISE (10u/min.) and default base pressure (50 microns). The On-Board *IS* Controller allows you to reprogram the settings, within limits. This is normally done prior to the start of a regeneration cycle. The On-Board *IS* Controller also allows you to delay that start and completion of regeneration cycle. This feature is desirable, for example, when you want to regenerate and start up your cryopump system during a week-end shutdown.

Regeneration Screen

The Regeneration screen allows the user to start or abort a group regeneration cycle. The current group regeneration state is also displayed.

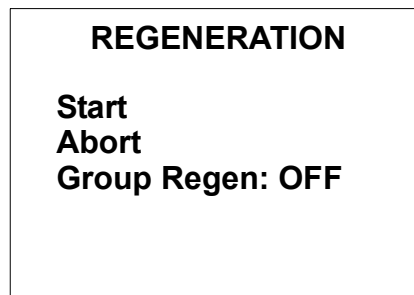

Figure 4-14: Regeneration Screen

Group Regeneration

The Group Regeneration screen allows the user to select the On-Board *IS* Cryopumps on the network to be regenerated.

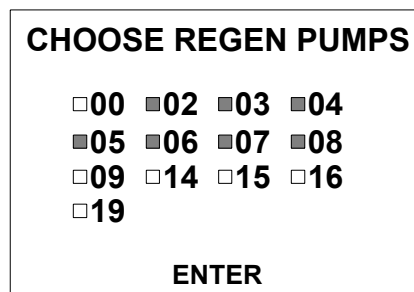

Figure 4-15: Group Regeneration Pumps Screen

Regeneration List Verification

The Regeneration List Verification screen displays the previously selected On-Board IS Cryopumps to be regenerated. A Fast or a Full regeneration cycle can then be selected.

NOTE: If NO is selected, the Regeneration screen appears.

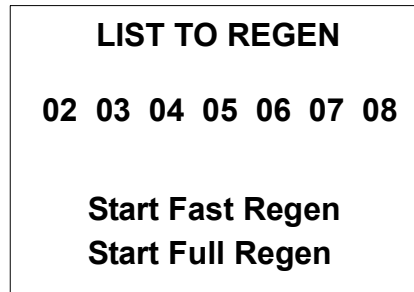

Figure 4-16: Start Fast Regeneration Cycle Screen

Regeneration Verification Screen

The Regeneration Verification screen allows the user to verify the regeneration cycle selected. Selecting *Yes* will initiate the desired regeneration cycle. Selecting *NO* returns the user to the previous screen.

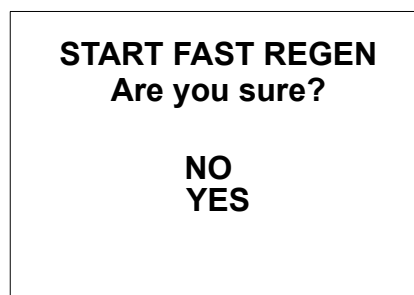

Figure 4-17: Regeneration Verification Screen

NOTE: If the selected On-Board IS Cryopumps cannot be regenerated, a screen appears explaining the reason.

Regeneration Abort

The Regeneration Abort screen verifies the user wants to abort a regeneration cycle. Selecting *YES* causes the regeneration cycle to be aborted. The user must press the *BACK* button to return to the Regeneration screen. Selecting *NO* causes the Regeneration Status screen to be displayed.

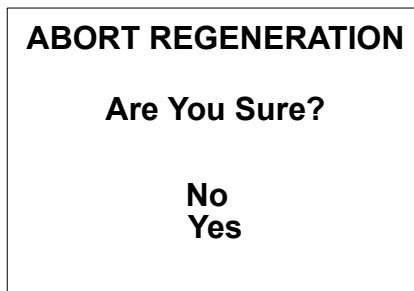

Figure 4-18: Regeneration Abort Screen

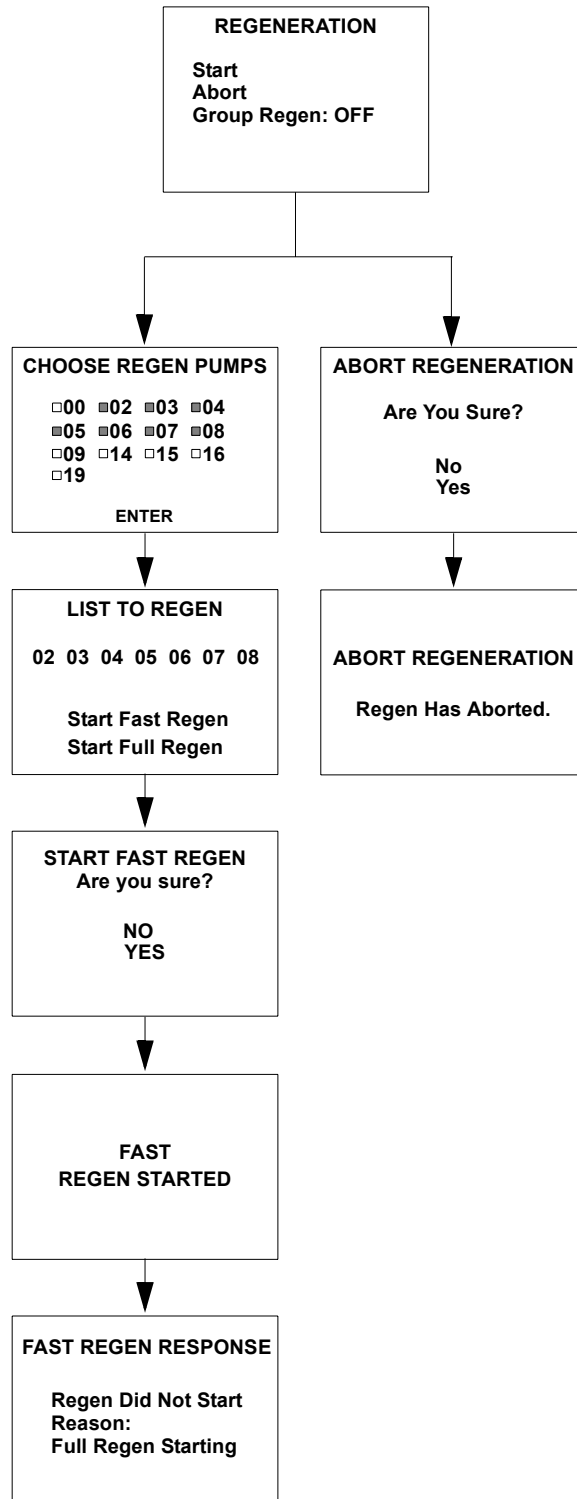

Figure 4-19: Regeneration Screens

Access Device Screen Description

The Choose Device screen allows a user to choose an individual On-Board *IS* Cryopump or other network device. The Choose Device display indicates the type and number of devices currently on the

On-Board *IS* Intercomponent Network.

CHOOSE DEVICE	
Pumps	12
Compressors	6

Figure 4-20: Choose Device Screen

Network Pumps

The Network Pumps screen allows the user to select a pump number from a list of pumps on the network.

NETWORK PUMPS				
00	01	03	05	06
07	08	09	10	11
13	16	18		

Figure 4-21: Network Pump Screen

Once the pump has been selected, the On-Board *IS* Cryopump information screen appears as shown in Figure 4-22.

PUMP 1	
1st Stage(K)	350
2nd Stage(K)	157
Vacuum(μ)	OFF
Regen State	
State Comment 1	
State Comment 2	

Figure 4-22: On-Board IS Pump Information Screen

Network Compressors

The Network Compressors screen allows the user to select an On-Board IS-1000 Compressor number from a list of pumps on the network.

NETWORK COMPRESSORS				
20	21	23	24	
29	30			

Figure 4-23: Network Compressor Screen

Once the compressor has been selected, the On-Board IS-1000 Compressor information screen appears as shown in Figure 4-24.

COMPRESSOR 20	
Supply Pressure	15
Return Pressure	20
Delta Pressure	5
Water In (F)	82
Water Out (F)	102
Operating Hours	123

Figure 4-24: On-Board IS-1000 Compressor Information Screen

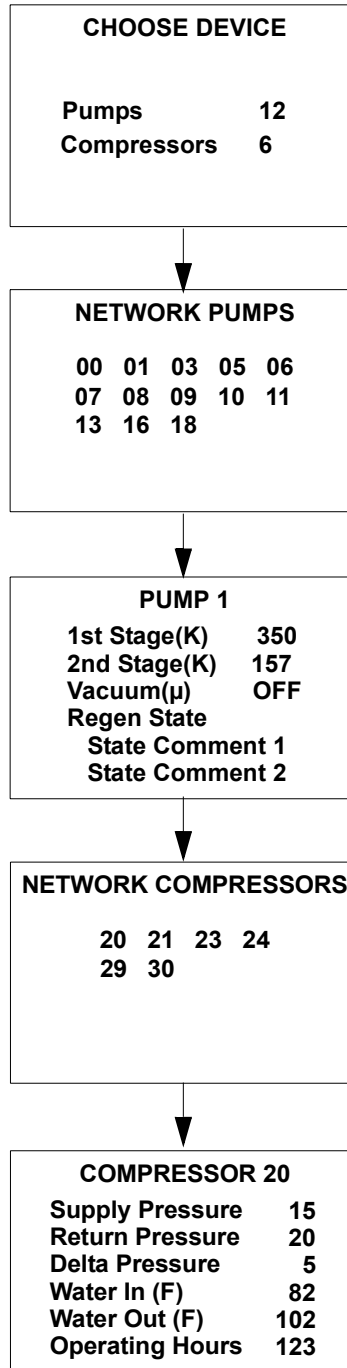

Figure 4-25: Access Network Device Screens

System Setup Screen Description

The System Setup screen provides access to regeneration, security, communication station ID, power failure and relay subsystem configurations. The screen is password protected.

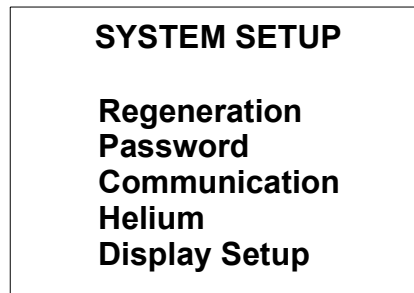

Figure 4-26: System Setup Screen

Regeneration Setup

The Regeneration Setup screen allows the user to configure regeneration parameters. Full coordination or power fail coordination are also controlled by this screen.

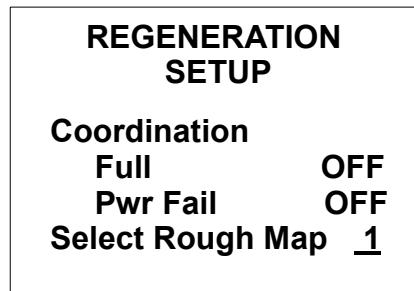
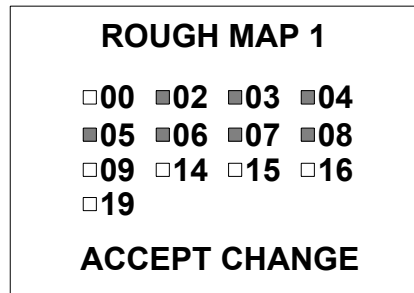

Figure 4-27: Regeneration Setup Screen

Rough Map

The Rough Map screen allows the user to select which On-Board *IS* Cryopumps will included in the rough map.



ROUGH MAP 1

00 02 03 04
05 06 07 08
09 14 15 16
19

ACCEPT CHANGE

Figure 4-28: Rough Map Screen

Once **ACCEPT CHANGE** has been selected, the rough map screen is displayed showing the On-Board *IS* Cryopumps included in the rough map.

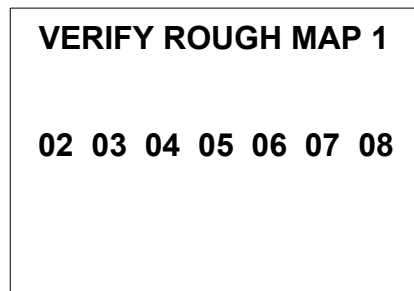

VERIFY ROUGH MAP 1

02 03 04 05 06 07 08

Figure 4-29: Verify Rough Map Screen

Password Setup

The Password Setup screen allows the user to establish or change a numeric password and enable or disable password protection.



Figure 4-30: Password Setup Screen

When password protection is turned ON, the user will be prompted to enter a password to access On-Board *IS* Controller software.



Figure 4-31: Entering a Password Screen

Once a password has been entered, a password confirmation screen appears.



Figure 4-32: Confirm Password Screen

Password Reset

If a password has been forgotten, the password can be reset to a factory default value of 9999. The password reset function can be implemented from the Main screen by pressing the *Left* and *Right* arrow keys simultaneously. A password verification screen appears that asks the user if the password is to be reset. Answering Yes will reset the password to 9999. Answering NO will not change the password.

Communication

The Communication screen allows the user to set the communication baud rate and to create a Virtual WinTalk session with the On-Board *IS* Controller.

Baud Rate

The On-Board *IS* Controller determines which ports are available (a minimum of two and maximum of three) and lists the ports on the Communication screen.

COMMUNICATION Set Port BAUD Rate:		
Host	0	9600
Service	1	9600
Aux	2	9600

Figure 4-33: Communication Baud Rate Screen

Helium

The Helium screen allows the user to select which helium map to configure. Enter the number of the helium map and press enter to view the helium map.

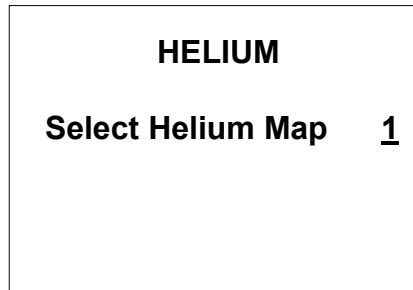

A rectangular screen with a black border. At the top center, the word "HELIUM" is displayed in bold. Below it, the text "Select Helium Map" is followed by the number "1" which has a vertical cursor bar to its left.

Figure 4-34: Choosing Helium Maps Screen

Choose Helium Map - Pumps

The Choose Map Pumps screen allows the user to select which On-Board *IS* Cryopumps will included in the helium map.

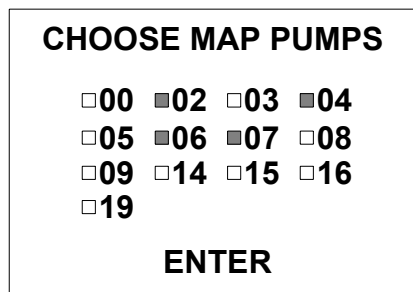

A rectangular screen with a black border. At the top center, the text "CHOOSE MAP PUMPS" is displayed in bold. Below it, there is a grid of pump numbers: 00, 02, 03, 04, 05, 06, 07, 08, 09, 14, 15, 16, and 19. Each number is preceded by a small square checkbox. The checkboxes for 02, 06, and 07 are filled with a grey color, while the others are empty. At the bottom center of the screen, the word "ENTER" is displayed in bold.

Figure 4-35: Choosing Helium Maps Screen

Choose Helium Map - Compressors

The Choose Compressors screen allows the user to select which On-Board *IS* Compressors will included in the helium map.

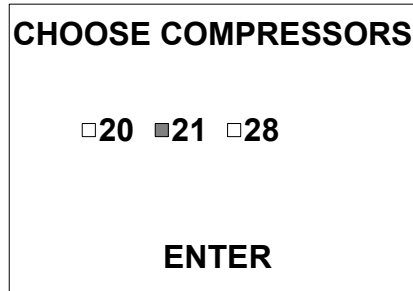

Figure 4-36: Choosing Helium Maps Screen

Verify Helium Map Setup

The Verify Helium Map Setup screen allows the user verify and accept the On-Board *IS* Cryopumps and On-Board *IS*-1000 Compressors in the helium map.

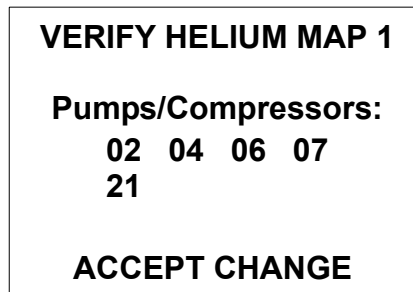

Figure 4-37: Verify Helium Map Screen

Display Setup

The IS Remote Setup screen allows the user to configure the On-Board *IS* Remote parameters. Refer to Table 4-1 for parameter values.

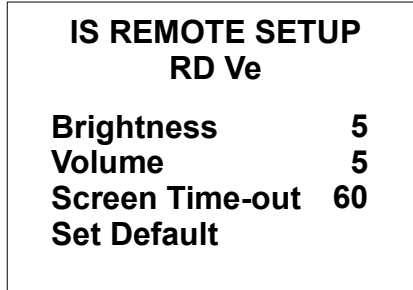

Figure 4-38: On-Board *IS* Remote Setup Screen

Table 4-1: IS Remote Setup Parameters

Parameter	Default Value	Range of Values
Brightness	0	0 (Brightest) - 15
Volume	16	0 - 16 (Loudest)
Screen Time-out	15	0 - 60 minutes

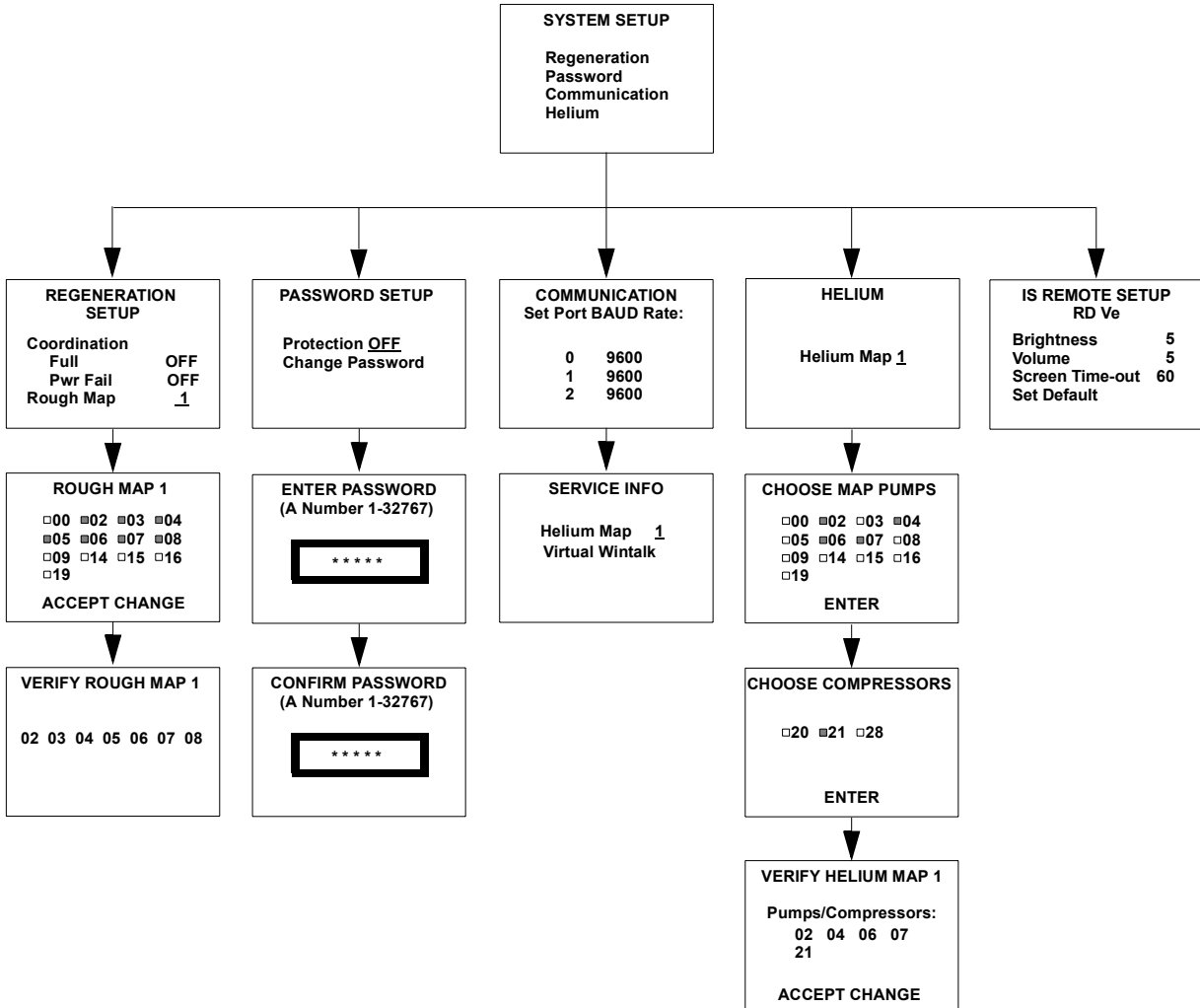

Figure 4-39: System Setup Screens

System Setup Screen Description

Section 5 - On-Board IS Cryopump Screen Descriptions

Introduction

Section 5 provides you with a description of programming and operation information for On-Board IS FastRegen Control Module software when the On-Board IS Remote is connected to a specific On-Board IS Cryopump.

NOTE: The On-Board IS Cryopump Module contains factory set parameters. If the default parameters need to be changed for your process, then the Remote Display must be connected to each On-Board IS Cryopump and the regeneration parameters can be changed.

Selecting Screens and Changing Parameters

Regardless of the screen, the method by which screens are selected and values are changed is the same. Use the following procedures to select screens and change values on the Remote Display shown in Figure 5-1.

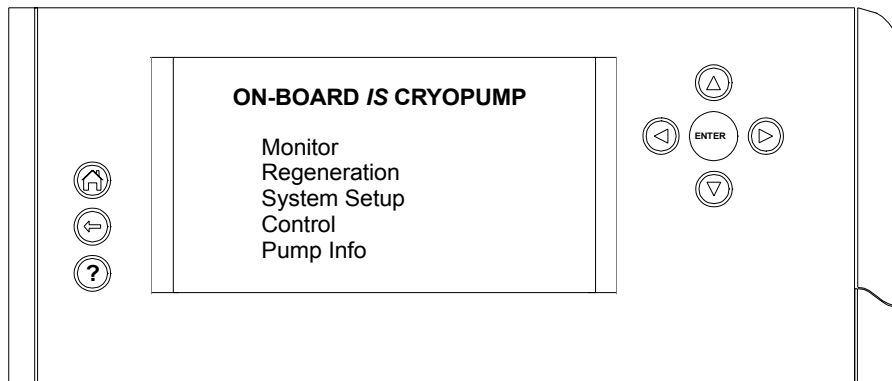

Figure 5-1: On-Board IS Remote

Screen Selection

1. Using the arrow buttons, select the desired screen to be viewed.
2. Press the **ENTER** button. The selected screen will appear.
3. Use the arrow buttons to move the cursor to the selected screen item.

4. Press the **ENTER** button. The selected screen appears.

Changing a Screen Parameter

1. Using the arrow buttons, select the desired screen to be viewed.
2. Press the **ENTER** button. The selected screen will appear.
3. Use the arrow buttons to move the cursor under the parameter to be changed.
4. Press the **ENTER** button. The parameter to be changed will be underlined.
5. Use the arrow buttons to change the value.
6. Press the **ENTER** button. The parameter will be changed to the new value.

NOTE: When the On-Board IS Remote is idle for 15 minutes, a screen saver will be activated and will dim the display to its lowest level and scroll from right to left across the screen. Pressing any one of the buttons on the remote display will turn the screen saver off and return the screen to its normal brightness.

MONITOR Function

The MONITOR function allows you to observe the cryopump state, regeneration information, valve status and temperature control information of the On-Board IS Cryopump.

NOTE: Screen parameters cannot be changed while using the MONITOR function.

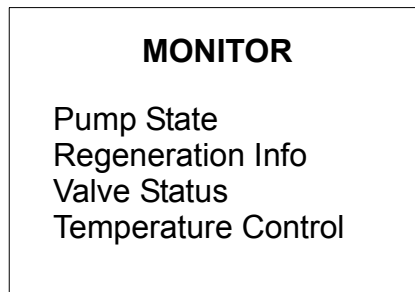

Figure 5-2: Monitor Screen

Pump State

The Pump State screen allows the user to view T1 and T2 temperatures, Cryopump thermocouple gauge, and the current regeneration state. This information will be continuously updated. If the temperature of the first or second goes below 5K, the display will indicate *Open*. If the temperature of the first or second goes above 350K, the display will indicate *Short*. If the Cryopump thermocouple gauge is disabled, the display will indicate OFF.

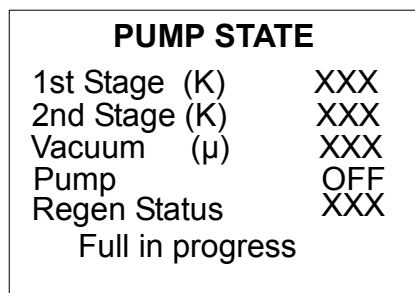
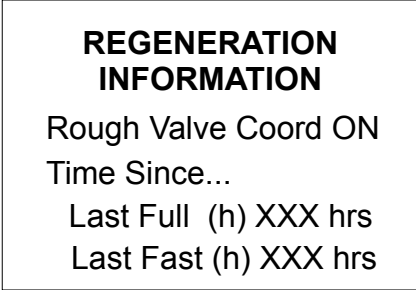

Figure 5-3: Pump State Screen

Regeneration Information

The Regeneration Information screen displays the current state of the Rough Valve Coordination feature and the time since the last Fast and Full regeneration cycle.



**REGENERATION
INFORMATION**
Rough Valve Coord ON
Time Since...
Last Full (h) XXX hrs
Last Fast (h) XXX hrs

Figure 5-4: Regeneration Information Screen

Valve Status

The Valve Status screen displays the status of the rough, purge, exhaust purge and gate valves.

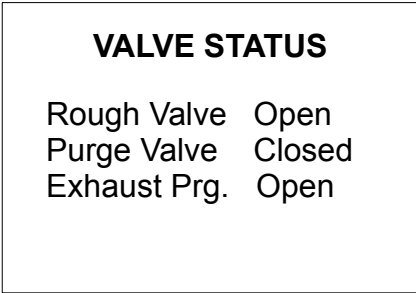

VALVE STATUS
Rough Valve Open
Purge Valve Closed
Exhaust Prg. Open

Figure 5-5: Valve Status Screen

Temperature Control

The Temperature Control screen displays the first and second stage temperatures and set point values.

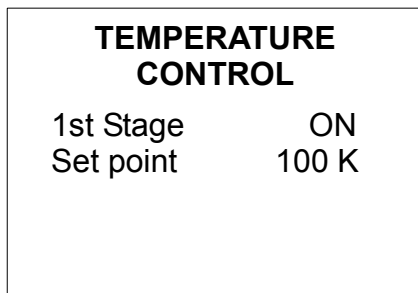

Figure 5-6: Temperature Control Screen

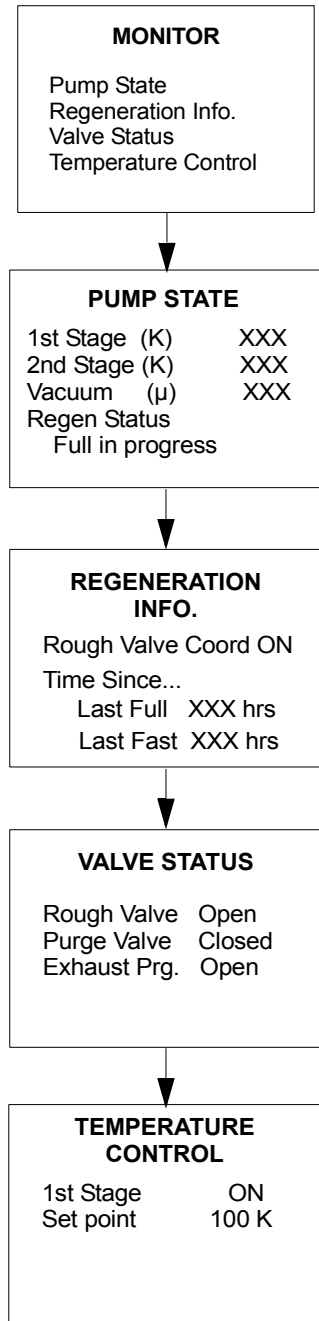

Figure 5-7: Monitor Function Screens

Regeneration Function

The REGEN function of the On-Board *IS* FastRegen Control Module allows you to initiate a Full or Fast regeneration cycle on your cryopump. Once initiated, the On-Board *IS* System automatically sequences your pump through the various phases of the regeneration cycle.

A Full regeneration cycle allows the cryopump to warm-up to room temperature so that both gases and water vapor collected on the arrays are purged from the pump. Once the contaminants are purged, the cryopump becomes cold again.

In many cases, there is little water pumped and so it is not necessary to warm the pump to room temperature. If the pump is primarily filled with such gases as argon, nitrogen or hydrogen, then the pump can be regenerated using a Fast Regeneration cycle. A Fast regeneration cycle only warms the cryopump enough to release the gases condensed on the arrays and trapped within the charcoal. This allows the regeneration cycle to be completed in less than an hour in many cases.

One of the key process steps in a Fast regeneration cycle is the removal of the condensed gas by means of the roughing pump. It is important that the condensed gas be removed quickly as the pump warms up, and that a certain minimum base pressure in the cryopump be achieved quickly. Because of these requirements, it is necessary that cryopumps that share a common roughing pump be coordinated. That is, the start of regeneration, the opening and closing of the roughing valves and the purge valves on multi-pump On-Board *IS* Cryopump systems must happen at very specific times and in unison. These are coordinated by the On-Board *IS* Controller. The roughing valves are coordinated by the On-Board *IS* Controller for both Fast and Full regeneration cycles although for different reasons.

Typically, regeneration is a function that is part of overall periodic maintenance for a cryopump system: frequency is dependent upon your particular pump application, but the cycle can be manually started at any time.

The REGEN program incorporates a number of parameters that are preset at the factory, such as RATE-OF-RISE (10u/min.) and default base pressure (50 microns). The On-Board *IS* FastRegen Control Module allows you to reprogram the settings, within limits. This is normally done prior to the start of a regeneration cycle. The On-Board *IS* FastRegen Control Module also allows you to delay that start and completion of regeneration cycle. This feature is desirable, for example, when you want to regenerate and start up your cryopump system during a week-end shutdown. You can reset the REGEN parameters by pressing the REGEN key and stepping through the REGEN screen as shown in [Table 5-1](#).

Regeneration Screen

The Regeneration screen allows the user to start a Fast or Full regeneration cycle, or abort a cycle that is running. The screen is password protected if the password option on the Security screen is ON. If a regeneration cycle is being aborted, the user will be asked to confirm the abort.

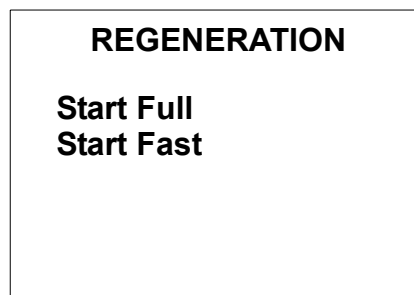

Figure 5-8: Regeneration Screen

Start Full Regeneration

The Start Full Regeneration screen requires the user to confirm the start of a Full regeneration cycle. If NO is selected, the Regeneration screen appears.



Figure 5-9: Start Full Regeneration Cycle Screen

Start Fast Regeneration

The Start Fast Regeneration screen requires the user to confirm the start of a Fast regeneration cycle.

NOTE: If NO is selected, the Regeneration screen appears.

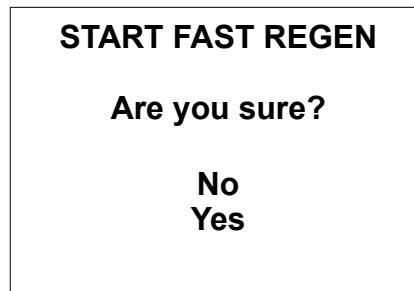

Figure 5-10: Start Fast Regeneration Cycle Screen

Regeneration Status

The Regeneration Status screen is constantly updated while the current regeneration cycle is in progress. The regeneration cycle can also be aborted from this screen. If a regeneration cycle is being aborted, the user will be asked to confirm the abort.

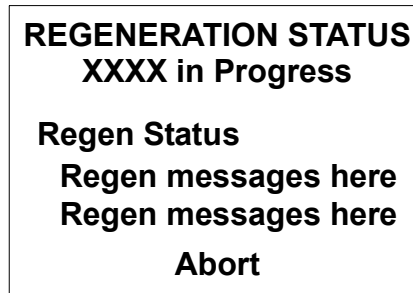

Figure 5-11: Regeneration Status Screen

Regeneration Abort

The Regeneration Abort screen verifies the user wants to abort a regeneration cycle. If YES is selected, the regeneration cycle will be aborted. The user must press the BACK button to return to the Regeneration screen. If NO is selected, the Regeneration Status screen is displayed.

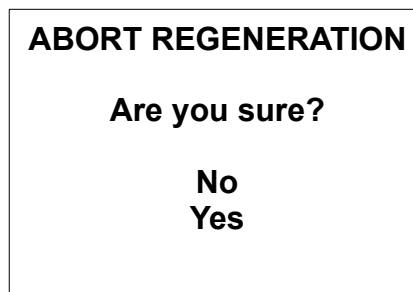

Figure 5-12: Regeneration Abort Screen

Table 5-1: Default Regeneration Parameters

REGEN Parameter	Default Value	Range of Values	Fast	Full
Extended Purge	1 minute	0 - 9999 minutes		✓
Repurge	15 minutes	0 - 9999 minutes		✓
Repurge Cycles	15	0 - 20 cycles		✓
Base Pressure	50 microns	25 - 200 microns	✓	✓
Rate-of-Rise (ROR)	10 microns/minute	1 -100 microns/minute		✓
ROR Cycles	20	0 - 40 cycles		✓
Rough Test	150 seconds	10 - XXX seconds	✓	
Rough Coordination	OFF	ON/OFF	✓	✓
Start Delay	0	0 - XXX.9 hours	✓	✓
Restart Delay	0	0 - XXX.9 hours		✓
Power Fail Recovery	OFF	ON/OFF/COOL	✓	✓
Power Fail Recovery Temperature	25K	0 - 80K	✓	✓

NOTE: The check mark (✓) in the Fast and Full columns in Table 5-1 indicate whether the regeneration parameters are used during the Fast and/or Full regeneration cycles.

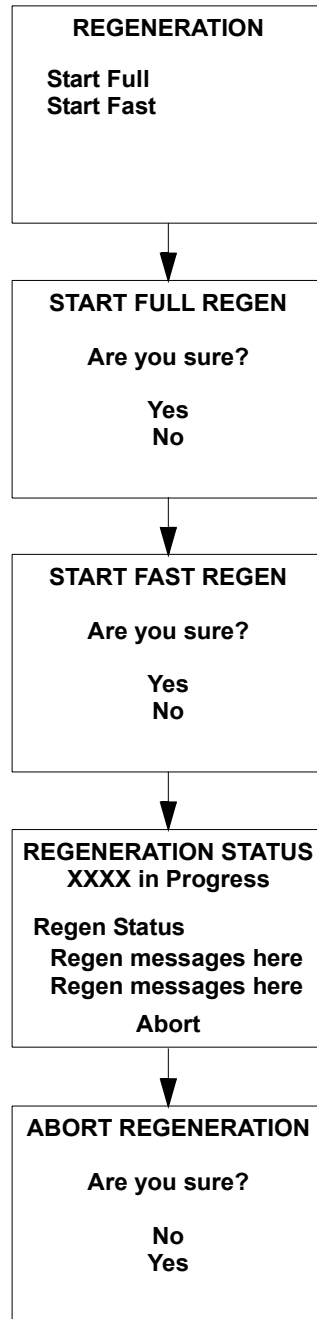

Figure 5-13: Regeneration Function Screens

System Setup Function

The System Setup screen provides access to regeneration, security, communication station ID, power failure and relay subsystem configurations. The screen is password protected.

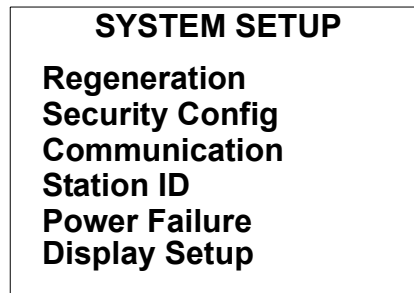

Figure 5-14: System Setup Screen

Regeneration Setup

The Regeneration Setup screen allows the user to select the Purge, Roughing and Regeneration Delay sub screens.

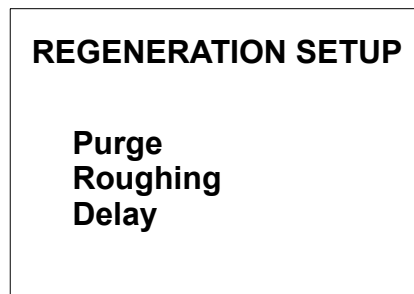

Figure 5-15: Regeneration Setup Screen

Purge Setup

The Purge Setup screen allows the user to set the extended time, repurge time and number of repurge cycles. The purge setup values are listed in [Table 5-2](#).

PURGE SETUP	
Extended	(m) XXX
Repurge	(m) XXX
Repurge Cycles	XX

Figure 5-16: Purge Setup Screen

Table 5-2: Purge Setup Parameters

Parameter	Minimum	Maximum	Units
Extended Purge	0	9999	Minutes
RePurge	0	9999	Minutes
Repurge Cycles	0	20	Cycles

Rough Setup

The Rough Setup screen allows the user to set the base pressure, maximum rate-of-rise, maximum rate-of-rise cycles, rough test values and turn Rough Coordination ON or OFF. The Roughing Setup values are listed in Table 5-3.

ROUGH SETUP	
Base Pressure (μ)	XXX
ROR Max (μ /min)	XXX
ROR Cycles	XX
Rough Test (s)	XXX
Rough Coord	OFF

Figure 5-17: Rough Setup Screen

Table 5-3: Roughing Setup Parameters

Parameter	Minimum	Maximum	Units
Base Pressure	25	200	Microns
Rate of Rise	1	100	Microns/Minute
Rate of Rise Cycles	0	40	Cycles
Fast Rough Test	10	999	Seconds
Rough Valve	OFF	ON	-

Delay Setup

The Delay Setup screen allows the user to set the start delay and restart delay parameters. The Delay Setup parameters are listed in Table 5-4.

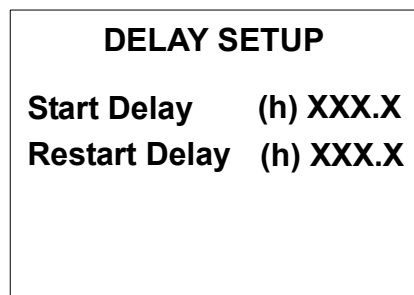

Figure 5-18: Delay Setup Screen

Table 5-4: Delay Setup Parameters

Parameter	Minimum	Maximum	Units
Start Delay	0	999.9	Minutes
Re-Start Delay	0	999.9	Minutes

Security Config

The Security Setup screen allows the user to turn ON password protection, change passwords and to lock/unlock regeneration and relay settings. Password protection provides restricted access to these On-Board IS Cryopump configuration parameters. Once password protection is turned ON, the user will have to enter a valid password to gain access.

NOTE: In the event a password is forgotten, the password can be reset to a default value (9999). Refer to Resetting the Password in this section for more information.

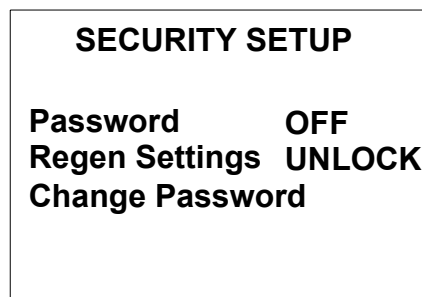

Figure 5-19: Security Setup Screen

Change Password

If Password Protection is turned ON, or the *Change Password* selection was made from the Security Setup screen, the user will be prompted to enter a password.

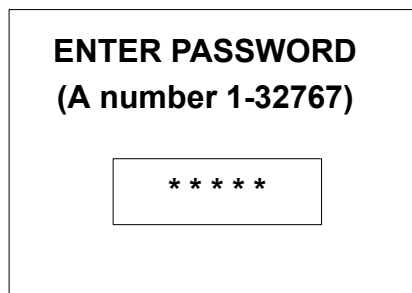

Figure 5-20: Change Password Screen

Once the new password has been entered, the user will be asked to confirm the password that was entered.

Communication

The Communication Setup screen allows the user to configure the baud rate of the external RS-232 port. The baud rate values are listed in Table 5-5.

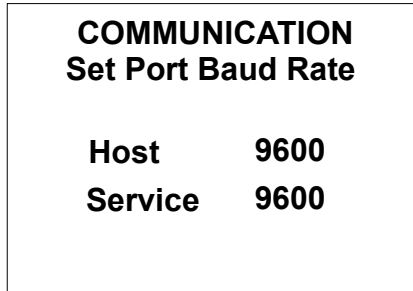

Figure 5-21: Communication Setup Screen

Table 5-5: Communication Baud Rate Values

Parameter	Choices
Baud Rate	2400, 9600, 19200, 38400

Station ID

The station ID screen allows the user to identify the vacuum system chamber on which the On-Board *IS* Cryopump has been installed.

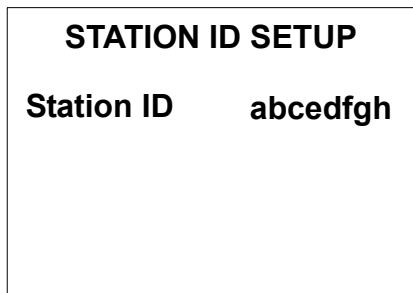

Figure 5-22: Station ID Setup Screen

Power Failure

The Power Failure setup screen allows the user to configure power failure parameters. Choices for recovery are; ON, OFF and Cool. If ON is selected and the power is interrupted and then restored, the second stage temperature will be monitored. If the current temperature of the second stage exceeds the power fail temperature limit, a regeneration cycle will be performed. The range of temperature values are listed in Table 5-6.

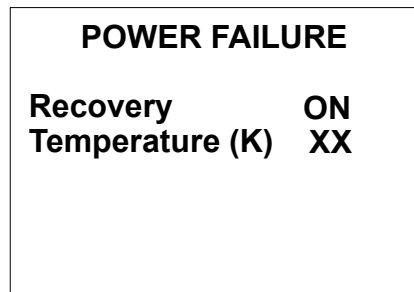

Figure 5-23: Power Failure Screen

Table 5-6: Power Failure Temperature Ranges

Parameter	Minimum	Maximum	Units
Temperature	0	80	K

IS Remote Setup

The IS Remote Setup screen allows the user to configure the On-Board IS Remote Display parameters. Refer to Table 5-7 for parameter values.

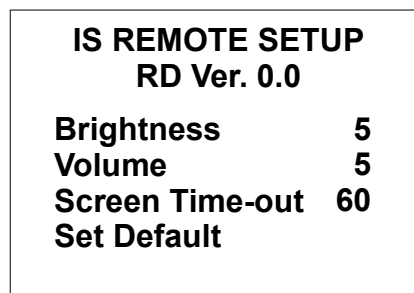

Figure 5-24: Display Setup Screen

Table 5-7: Display Setup Parameters

Parameter	Default Value	Range of Values
Brightness	0	0 (Brightest) - 15
Volume	16	0 - 16 (Loudest)
Screen Time-out	15	0 - 60 minutes

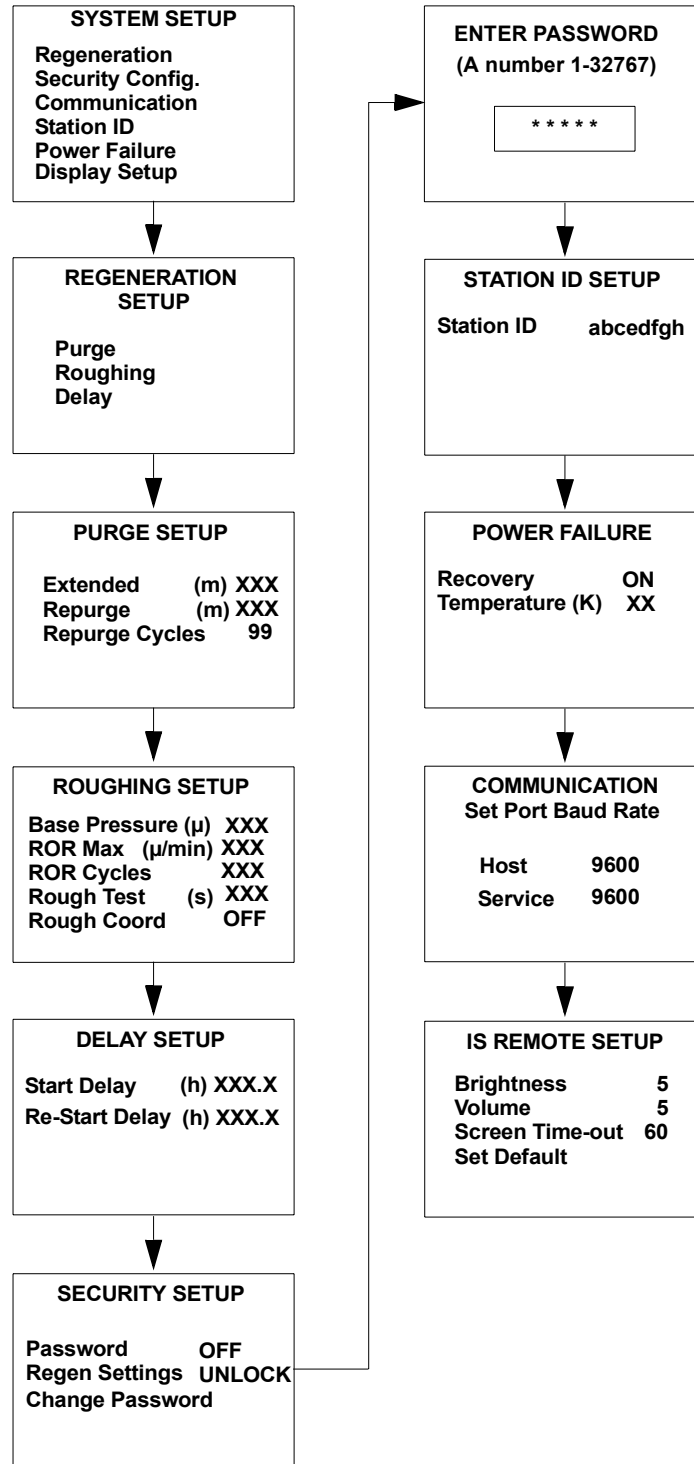



Figure 5-25: System Setup Function Screens

Control Function

The Control function allows the user to turn the On-Board *IS* Cryopump motor, thermocouple gauge and relays ON or OFF, and open or close the rough and purge valves. The Control parameters are listed in Table 5-8.

CONTROL	
Motor	On
Cryo TC	Off
Rough Valve	Open
Purge Valve	Closed
HFI Status	OK

Figure 5-26: Control Screen



CAUTION

The Control Function will not allow the Cryo TC to be turned ON when the On-Board *IS* Cryopump second stage temperature is above 20K.



CAUTION

The Control Function will not allow the Rough or Purge valves to be opened when the On-Board *IS* Cryopump motor is ON to prevent possible cryopump contamination.

Table 5-8: Control Parameters

Parameter	Value
Motor	ON/OFF
Cryo TC	ON/OFF
Rough Valve	Open/Closed
Purge Valve	Open/Closed

Pump Information Screen

The Pump Information Screen allows the user to view the pump serial number, part number, network address, hours of operation, and software revision.

PUMP INFO	
S/N	??????
Address	01
Operating Time	XXX
Software Rev.	ABxx.xx

Figure 5-27: Pump Information Screen

Section 6 - Troubleshooting Procedures

Introduction

Section 6 provides information on how to troubleshoot Helix Intercomponent Network communication problems and provides references to on-line product manuals for troubleshooting the On-Board IS Cryopump or On-Board IS-1000 Compressor.

*NOTE: Refer to **Troubleshooting Cryopumps or Compressors** within this section for more information.*

*NOTE: You can also refer to **Appendix A** for customer support information and contact Helix Technology Corporation for assistance if required.*

Helix Intercomponent Network

Refer to Table 6-1 if you are experiencing Helix Intercomponent Network communication problems.

Table 6-1: Helix Intercomponent Network Troubleshooting Procedures

Problem	Possible Cause	Corrective Action
1. On-Board IS Cryopumps are not visible on On-Board IS Controller screens.	1. A network terminator is not installed in the last cryopump on channel A or B.	1. Refer to the On-Board IS Cryopump Quick Installation Guide and install a network terminator in the last cryopump on channels A or B.
	2. The cryopump is connected to channel C.	2. Disconnect the cryopump from channel C and connect it to channels A or B.
	3. Defective network cable.	3. Replace network cable.

Table 6-1: Helix Intercomponent Network Troubleshooting Procedures (Continued)

Problem	Possible Cause	Corrective Action
2. Compressors are not visible on On-Board <i>IS</i> Controller screens.	1. A network terminator is not installed in the last compressor on channel C. 2. The compressor is connected to channels A or B. 3. Defective network cable.	1. Refer to the On-Board <i>IS</i> -1000 Compressor Quick Installation Guide and install a network terminator in the last compressor on channel C. 2. Disconnect the compressor from channels A or B and connect it to channel C. 3. Replace network cable.
3. Status LED III on the On-Board <i>IS</i> Controller is <i>not</i> blinking.	1. Channel A, B or C network cable is disconnected from controller. 2. Defective network cable.	1. Connect the network cable(s) to the controller. 2. Replace network cable.

Appendix A - Customer Support Information

Customer Support Center Locations

To locate a Customer Support Center near you, please visit our website www.helixtechnology.com on the world wide web and select *CONTACT* on the home page.

Guaranteed Up-Time Support (GUTS)

For 24 hour, 7 day per week Guaranteed Up-Time Support (GUTS) dial:

800-367-4887 - Inside the United States of America

508-337-5599 - Outside the United States of America

Product Information

Please have the following information available when calling so that we may assist you:

- Product Part Number
- Product Serial Number
- Product Application
- Specific Problem Area
- Hours of Operation
- Equipment Type
- Vacuum System Brand/Model/Date of Manufacture

E-mail

For your convenience, you may also e-mail us at:

techsupport@helixtechnology.com

Index

A

Address
 verifying 1-9
 Address switch 1-6

C

Controller
 monitor screen 4-2
 Controller main screen
 description 4-1
 Controller network devices screen
 description 4-4
 Controller network status screen
 description 4-2
 Controller pump temperature screen
 description 4-3
 Controller screens
 access device 4-14
 choose helium map compressors 4-22
 choose helium map pumps 4-21
 communication 4-20
 compressor pressures 4-3
 display setup 4-23
 group regeneration 4-10
 helium 4-21
 helium management 4-6
 network compressors 4-5, 4-15
 network devices 4-4
 network pumps 4-4, 4-14
 password setup 4-19
 regeneration 4-5
 regeneration abort 4-12
 regeneration list verification 4-11
 regeneration setup 4-17
 regeneration verification 4-11
 regeneration, description 4-9
 rough map 4-6, 4-18
 show helium maps 4-7
 system setup 4-17
 verify helium map setup 4-22
 Cryopump

monitor function 5-3
 Cryopump Parameters, screen
 changing 5-1
 Cryopump screens
 change password 5-16
 communication setup 5-17
 control function 5-21
 delay setup 5-15
 IS remote setup 5-18
 power failure 5-18
 pump information 5-22
 pump state screen 5-3
 purge setup 5-13
 regeneration abort 5-10
 regeneration function 5-7
 regeneration information 5-4
 regeneration screen 5-8
 regeneration setup 5-13
 regeneration status 5-10
 rough setup 5-14
 security setup 5-16
 selecting and changing parameters 5-1
 start fast regeneration 5-9
 start full regeneration 5-9
 station ID 5-17
 system setup function 5-13
 temperature control 5-5
 valve status 5-4

E

Equipment address
 verifying 1-9

H

Helium maps
 creating 2-5
 using 2-3
 Helix Intercomponent Network
 address settings 1-3
 network terminator 1-3
 On-Board IS Cryopumps 1-3

On-Board IS-1000 Compressor 1-3

M

Monitor function 5-3

O

On-Board IS Cryopump

first and second stage temperatures 1-10

On-Board IS Remote 1-7

On-Board IS-1000 Compressor

delta pressure 1-11

helium supply and return pressure 1-11

operating hours 1-11

water in/out temperature 1-11

P

Parameters

changing 1-7

Passwords

setting 1-12

Power

shutting off 1-8

turning on 1-8

Pump state screen

description 5-3

R

Regeneration

full regeneration cycle 3-6

parameters 3-1

Regeneration Maps 3-3

Roughing maps

using 2-1

Rouging maps

creating 2-3

S

Screen savers 1-7

Screens

pump state 5-3

selecting 1-7

Switch

address 1-6

T

Troubleshooting 6-1

V

verifies 4-12